

NJ Arts Access Task Force

ADA SELF-ASSESSMENT SURVEY AND PLANNING TOOL

(March 2003)

DISCLAIMER: Information included in this document is intended as a resource and is for informational purposes only. It is neither a determination of your legal rights and responsibilities under state or federal access laws nor binding on any agency with enforcement responsibilities.

For complete ADA regulations, standards and guidelines contact the U.S. Department of Justice ADA Information hotline at 800-514-0301 (voice) or 800-514-0383 (TTY) or visit the Department of Justice ADA information website at www.ada.gov.



The New Jersey Arts Access Task Force is a cosponsored project of the New Jersey State Council on the Arts and the New Jersey Theatre Alliance



Contact the NJ Arts Access Task Force at 973-593-0189 to obtain this Self-Assessment in alternate formats

TABLE OF CONTENTS

Introduction to the Americans With Disability Act	Page 1
Introduction to the NJAATF ADA Self Assessment Survey and Planning Tool	Page 2
How To Use the Self-Assessment Tool	Page 3
Organization Information	Page 5
PART ONE: MANAGEMENT PRACTICES, PROGRAMS AND SERVICES	Page 6
Management Practices: Policies	Page 6
Management Practices: Employment	Page 9
Management Practices: Grievance Procedure	Page 11
Effective Communication: Publications	Page 12
Effective Communication: Marketing/Outreach	Page 14
Effective Communication: Websites	Page 16
Effective Communications: Meetings	Page 18
Programs and Services: Performing Arts Events	Page 19
Programs and Services: Visual Arts/Museums	Page 22
Programs and Services: Transportation	Page 25
Touring and/or Education Companies	Page 26
County Arts Agencies	Page 27
PART TWO: FACILITY	
Introduction to Facility Questions	Page 29
Facility Information	Page 30
Architectural Barrier Removal/Physical Accessibility	
Priority 1: Accessible Approach and Entrance	Page 32
Parking and Drop off Areas	Page 32
Route of Travel and Accessible Entrances	Page 33
Priority 2: Access to Programs, Goods and Services	Page 35
Interior Spaces	Page 35
Box Office/Information Desk/Lobby/Reception Area, etc.	Page 38
Assembly Spaces	Page 39
Exhibition Spaces	Page 41
Alarms/Safety	Page 44
Priority 3: Usability of Restrooms	Page 45
Priority 4: Additional Access	Page 46
Technical Facilities: Stages & Dressing Rooms	Page 47
APPENDIX	
NJ Census Data for People with Disabilities	Page I
Sample ADA Coordinator Job Description	Page ii
Fact Sheet 3: Communicating with People with Disabilities	Page iii-v
Grievance Procedure Samples 1 & 2	Page vi-viii
Sample Contract Rider for Touring Companies	Page ix
ADAAG Figures: Parking	Page x
ADAAG Figures: Ramps and slopes	Page x
ADAAG Figures: Clear Doorway Width and Depth	Page xi
ADAAG Figures: Protruding Objects	Page xii-xiii

ADAAG Figures: Wheelchair Turning Space	Page xiv
ADAAG Figures: Wheelchair Seating Spaces	Page xiv
Comfortable Viewing Zone	Page xv
Exhibit and Display Cases	Page xvi
ADAAG Figures: Water Closets	Page xvii
ADAAG Figures: Toilet Stalls	Page xviii
ADAAG Figures: Lavatory clearances	Page xix

RESOURCES

NJ Arts Access Task Force	Page A
County Offices for the Disabled	Page B
Independent Living Centers	Page C
Resources for Developing Accessible Web Sites	Page E
Resources relating to Museums and ADA	Page F
FM Assistive Listening Equipment Available for Loan	Page G

NJ Arts Access Task Force

ADA SELF-ASSESSMENT SURVEY AND PLANNING TOOL

(March 2003)

AN INTRODUCTION TO THE AMERICANS WITH DISABILITY ACT

The Americans with Disabilities Act (ADA) was signed into law on July 26, 1990 and took effect in January 1992. It is admittedly the most comprehensive formulation of civil rights for people with disabilities in the history of the United States.

According to the 2000 US Census, more than 1.4 million or 16.4% of New Jersey's citizens have some kind of physical, hearing, vision, cognitive, or mental disability. *(See Appendix Page i)* However, this figure does not adequately express the potential impact of ADA on our citizenry as it does not take into account that virtually every individual is touched at one time or another by the experience of disability, either personally or via a family member. The ADA's far-reaching provisions for employment, public accommodations, state and local government, transportation and telecommunications, therefore, have the potential to benefit almost everyone. Clearly, not only is ADA compliance the law and a social responsibility, it also makes good business sense. There is tremendous potential for welcoming a large population to your organization's art form, which previously was unable to access your programming. Furthermore, accommodations made for people with disabilities have universal benefits for people without disabilities. For instance, people pushing strollers and making deliveries have benefited greatly from ramps and curb cuts. Approaching ADA compliance from the point of view of developing an inclusive, universal environment and experience yields both creative and effective solutions to barrier removal.

As a not-for-profit arts organization, the ADA applies to you. The following brief overview of the law will help define how you fit into ADA regulations:

Title I mandates equal opportunity in employment. Employers with 15 or more employees are covered. (Please note, if you have less than 15 employees, other aspects of the legislation require employment compliance.)

Title II regulations require all state and local governmental public entities to make all programs, services and activities (including employment) accessible to people with disabilities. Title II also identifies steps that must be undertaken to comply with ADA. These include designation of an ADA Coordinator, policy review, establishment of an internal grievance procedure, and completion of both a self-evaluation and transition plan for compliance.

Title III covers all organizations of public accommodation. This Title mandates that theatres, museums, galleries, and all other places of public accommodation to remove architectural barriers where readily achievable and otherwise ensure nondiscrimination in their programs, services and activities. **When a Title III entity accepts funding from a governmental or Title II entity (such as the National Endowment for the Arts, the NJ State Council on the Arts, and county arts or history agencies), the Title III organizations must provide their products and/or services in the more stringent guidelines and priorities established for Title II.**

Title IV addresses telephone and television access for people with hearing and speech disabilities. It requires common carriers (telephone companies) to establish interstate and intrastate telecommunications relay services (TRS) 24 hours a day, 7 days a week. It provides access to all forms of transportation.

The Americans With Disabilities Act, like other civil rights legislation, was written with specific guidelines, yet with some broad strokes that have been fine-tuned via case law over the past 13 years. This also means that the law is “policed” by people who are trying to gain access versus a governmental entity. The tool for recourse is to file complaints directly with the organization via their grievance procedure, or in more serious cases, via a private lawsuit or with the Department of Justice. This is why it is imperative that every public entity completes a thorough self-evaluation and develops an ADA plan and grievance procedure.

Please note, when claiming that a provision of ADA compliance would result in a fundamental alteration to the program or an undue financial or administrative burden, the entity has an obligation to document the basis for its decision in a written statement and to demonstrate that all resources available for the funding and operation of the service, activity, or program were taken into consideration. The head of the entity or her or his designee must make the decision.

Claiming undue burden or fundamental alteration does not relieve a public entity/accommodation of all obligations to provide access to people with disabilities. Even if an entity is not able to undertake a particular measure to provide access, it must find other modifications that are feasible or readily achievable, to ensure that it does not discriminate against individuals with disabilities in programs, services, or activities.

NJAATF ADA SELF-ASSESSMENT SURVEY AND PLANNING TOOL

The NJ Arts Access Task Force has instituted this new self-assessment and ADA planning tool in direct response to comments from arts organizations as they endeavored to write a comprehensive and usable ADA plan that would assist them in their efforts to make their programs and facilities accessible to people with disabilities. In developing this tool with the NJ State Council on the Arts, the NJ Arts Access Task Force relied heavily on Federal, State, and service organization generated guidelines and survey tools such as the ADA Accessibility Guidelines (ADAAG), the National Endowment for the Arts’ *Arts Accessibility Checklist*, VSA arts of Massachusetts’ *Cultural Facility Access Survey and Teaching Instrument*, and Adaptive Environments Centers’ *ADA Title II Action Guide*. This document incorporates information and guidance from the above resources, as well as “best practices” and practical advice from Task Force members, arts leaders and people with disabilities. While it is impossible for this document to provide all necessary support material for each organization’s unique circumstances, this new tool provides a compilation of information that can be used by cultural institutions in their process of ensuring the arts in New Jersey are accessible to people with disabilities.

The NJAATF ADA self-assessment survey and planning tool was designed to serve multiple purposes. At first glance the volume of this document may seem daunting. However, the time investment yields many benefits:

1) Self- Assessment: Completion of this tool will assist your organization with a self-evaluation of your ADA policies, services, programs and facility(s) in regards to the Americans With Disabilities Act (ADA). If, in the course of completing this survey, you identify major problems with your facility, programs or policies, a person knowledgeable in accessibility compliance should be engaged to help you comply with local building codes and/or ADA legal requirements. Furthermore, working with an

expert in the field of ADA and/or universal design offers a deeper understanding of the areas of non-compliance and could assist your organization with complying, not only with the letter of the law, but also the spirit of the law.

2) ADA Plan for NJSCA Grant Requirement: Accurate completion of this survey will provide the necessary information and foundation needed to develop your organization's short and long-term plans to remove attitudinal, programmatic and physical barriers to patrons with disabilities. By asking specific questions regarding your facility, policies, programs and services, as well as management practices, this document helps take the mystery out of what is expected of your organization to have a basic ADA plan in place. To facilitate this process, guidance on how to use the self-assessment and what should be included in your ADA plan are provided within the tool, along with an informative appendix. **Guidance that pertains specifically to writing an ADA plan is in bold.** *Please note that the New Jersey State Council on the Arts does not require an organization to include this completed self-assessment as part of the submitted ADA plan.* Further ADA assistance can be attained by attending a NJ Arts Access Task Force Technical Assistance Workshop or by borrowing a copy of the Task Force Resource Guide, available through your local County Cultural & Heritage Commission. Further information regarding fulfilling grant requirements can be obtained from Don Ehman at (609) 292-6130 at the NJ State Council on the Arts or at their website www.njartscouncil.org.

3) Accessibility Resource Guide: Information included in this self-assessment can easily be transferred to a condensed survey that will be sent to your organization for the next edition of the *Discover Jersey Arts: Accessibility Guide*. This guide provides patrons with a "snapshot" of arts organizations' accessibility via the universal accessibility symbols. The next edition is expected to be issued in 2004.

How to use this Self-Assessment Survey Tool:

A) Prior to conducting your self-assessment, review the entire survey to familiarize yourself with the scope and content of the survey tool.

B) Designate the appropriate person(s) to conduct the survey. Depending on your organizational circumstances, the survey personnel could include the ADA Coordinator and staff members who have an intimate understanding of your facility, programming and policies. It is advantageous to include a member(s) of your ADA advisory committee. It is strongly encouraged that you invite additional people with various disabilities to assist in identifying barriers, developing solutions for removing these barriers, and setting priorities for implementing planned improvements.

C) You will need copies of this checklist, a pencil or pen, and a flexible steel tape measure.

There are two other measurement tool resources that may prove to be valuable to your process. Both are available for loan by calling your County Cultural and Heritage Agency, the NJ State Council on the Arts, and the NJ Arts Access Task Force.

- 1) The NJ Developmental Disabilities Council's Monday Morning Accessibility Campaign created a "Fanny Pack" containing tools for measuring and documenting problem spots. It comes with a disposable camera, laminated card with ADA Title III requirements, a pressure gauge, tape measure and a notebook and pencil.
- 2) The ADA Surveyor, developed by Gary Y. Kaplan F.A.I.A. architect, is a measuring instrument designed to assist the user in determining ramp slopes, rail diameters, heights of fixtures and devices, and clear openings of doors. (This tool is also available for purchase through the NJAATF.)

D) Complete both sections of the NJAATF ADA Self-Assessment Survey: I) Management Practices, Programs and Services, and II) Physical/Facility. This process will illuminate where your organization currently stands in relationship to ADA compliance. Space is provided for you to record actual measurements taken. Though some questions may not be directly applicable to your organization, be sure to review all guidance information to deepen your understanding of compliance issues. When possible, the applicable Americans With Disabilities Act Accessibility Guidelines (ADAAG) regulation is referenced with the survey question.

E) Questions you answer with a “yes” response are items to include in the “Status/Accomplishment” sections of your ADA plan. Be sure to note appropriate support information for your statements and timeframe of these accomplishments. When applicable, include your long-range goals to build on these accomplishments in your plan.

F) For each question you answer with a “no” response (that is applicable to your organization) make notes on what changes are determined to be necessary. These are areas of non-compliance or inaccessibility, which you will most likely want to address later in your long-range ADA plan.

ORGANIZATION INFORMATION

Type of Cultural Resource: (Check one box)

- Theatre
 Center/Presenters
 Craft/Folk Art
 Dance
 Music
 Visual Arts
 Arts Education
 Film/Media/Literature
 Service Organization

PLEASE CHECK BOX IF YOU ARE A Touring Company

Organization Name:			
Mailing Address:			
Name of Primary Venue: <i>(If different than above)</i>			
Venue Address:			
Telephone Number:	Box Office:	Administration:	TTY:
Fax Number:			
Executive Director:			
Executive Director Email Address:			
ADA Contact Person Name and Title:			
ADA Contact's Email Address:			
Website Address:			
# of years organization has been in operation			
Admission prices for programming:			
General Public Transportation Availability			
Driving Directions (if directions are too lengthy, just enter "contact organization for directions" and number to call for information)			
Number of Full Time Administrative Staff:			
Number of Part Time Administrative Staff:			
Number of members on Board of Directors			
Annual Operating Budget:			

Name of person(s) completing form:

Survey Date:

PART ONE: MANAGEMENT PRACTICES, PROGRAMS AND SERVICES

MANAGEMENT PRACTICES

GUIDANCE

POLICIES

Policies and practices need to be thoroughly examined and any policies identified as exclusionary or discriminatory should be modified as soon as possible and be incorporated into your ADA plan..

1. Do you have a Board of Directors approved nondiscrimination policy statement in place regarding accessibility?

- Yes
 No
 No Board

Policy approved by Board on:

An adequate ADA plan includes a general nondiscrimination and specific ADA nondiscrimination policy such as the one below:

[Organization Name] does not discriminate on the basis of disability in admission or access to, treatment of or employment in, its services, programs or activities. Upon request, accommodation will be provided to allow individuals with disabilities to participate in [Organization name] services, programs and activities.

[Organization name] has a designated coordinator to facilitate compliance with the Americans with Disabilities Act of 1990 (ADA), as required by Section 35.107 of the U.S. Department of Justice regulations, and to coordinate compliance with Sections 504 and 508 of the Rehabilitation Act of 1973.

While the above laws mandate equal access to people with disabilities, [Organization name] makes it a priority to establish a work place and environment that embraces the spirit of the law ensuring an optimal experience for all.

Upon request, information will be made available in alternative formats such as Braille, large print, audiotape and/or computer disc.

A strong ADA plan will preface the approved nondiscrimination policy with a more personalized statement about the organization's commitment to ADA compliance. ADA plans often fail to outline the attitudes, practices and policies already in place that provide a conducive environment for inclusion of people with disabilities.

2. Do any members of your Board of Trustees have a disability?

- Yes
 No

Having a person with a disability on the governing board will help educate the board on ADA issues and

		<p>build support for ADA efforts. Having the buy-in of the board will facilitate staff implementation of the long-range ADA plan.</p>
<p>3. Do you have an ongoing accessibility Advisory Committee?</p> <p>How many members do you have on this committee? _____</p> <p>How many of the committee members have disabilities?</p> <p>_____</p>	<p><input type="checkbox"/> Yes <input type="checkbox"/> No</p>	<p>An important first step to understanding how ADA relates to your organization is the establishment of an ADA Advisory committee/ board willing to help evaluate the accessibility of your programs, facilities and services. This committee can provide accessibility recommendations to your staff and board of directors, offer sensitivity and accessibility training, and become invaluable ambassadors, providing a vital link to audiences with disabilities once your facility and programs are accessible.</p> <p>This advisory group should include people with disabilities, representatives from organizations who serve people with disabilities and staff members responsible for administering ADA compliance and services to your patrons with disabilities, marketing, and raising funds to support your accessibility efforts.</p> <p>Inclusion of a list of Advisory Board members strengthens an ADA plan. At minimum, the plan should identify resources consulted to develop details of your long-range goals.</p>
<p>4. Do you have a staff person or board member who serves as ADA Coordinator and is specifically assigned to research and implement accessibility programs?</p>	<p><input type="checkbox"/> Yes <input type="checkbox"/> No</p>	<p>In most organizations, it would be difficult for any one individual to carry out all the required tasks of ADA compliance. It is the role of the ADA coordinator to coordinate the teamwork needed to implement the plan for compliance and to make sure that the proposed timeline is met.</p> <p>Some variables to consider in choosing an ADA Coordinator include:</p> <ol style="list-style-type: none"> 1) Adequate authority within the organization to obtain the participation required for the implementation of compliance requirements. Preferably, this person should have a strong connection to the leadership of the organization, since access policy begins from the top. 2) Though certainly not a prerequisite, a person with a disability or disability-related experience is likely to have more knowledge of discrimination and access issues. 3) An individual with a broad knowledge of the organization's activities, facility(s) and management procedures is likely to be more effective in obtaining necessary information and facilitating the development of creative solutions. 4) This individual should have a long-term commitment to the organization. With the high turnover rate in the arts, it is important to find an ADA coordinator who will be around to

		<p>implement ADA objectives and establish consistent programs and services.</p> <p>Often in organizations with a small staff, the ADA coordinator is the Executive Director or a qualified Trustee.</p> <p>A strong ADA plan should include the following:</p> <p>Person in charge of accessibility issues: Name: Title: Length of time in this position:</p>
<p>5. Do you have an ADA Coordinator job description?</p>	<p><input type="checkbox"/> Yes <input type="checkbox"/> No</p>	<p><i>See sample description in Appendix Page ii.</i></p>
<p>6. Do you train your staff and volunteers in disability awareness and service to patrons with disabilities?</p> <p>If Yes, how do you accomplish this? Check all that apply:</p> <p><input type="checkbox"/> Printed material (e.g. staff and volunteer manual, memo, brochure)</p> <p><input type="checkbox"/> Attend Arts Access Task Force or NJ State Council on the Arts cosponsored workshops and/or meetings # of workshops attended: _____ Year most recently attended workshop _____</p> <p><input type="checkbox"/> Offer in-house training sessions? Frequency of workshops: _____ Year of most recent workshop: _____</p> <p><input type="checkbox"/> Other: _____</p> <p>Who is involved in these training sessions? Check all that apply:</p> <p><input type="checkbox"/> Administrative Staff <input type="checkbox"/> Artistic Staff <input type="checkbox"/> Box Office Staff <input type="checkbox"/> Ushers <input type="checkbox"/> Volunteers <input type="checkbox"/> Regrantees <input type="checkbox"/> Other: _____</p>	<p><input type="checkbox"/> Yes <input type="checkbox"/> No</p>	<p>Once you are offering and publicizing accessible services and programs, it is imperative that all staff members who have patron contact receive sensitivity training to learn how to provide a positive experience to patrons with disabilities of any kind. Even if your organization is not yet fully accessible and does not yet offer services or programs for people with disabilities, your staff and volunteers need to be trained to accommodate patrons with disabilities who want to attend your offerings.</p> <p>Training sessions, at minimum, should include basic information about the Americans With Disabilities Act (ADA), disability etiquette, effective communications, and your organization's ADA policies and accessible services. Ideally, patrons with disabilities familiar with your organization should be part of the presenting panel. If you are offering a service that serves a particular constituency, i.e. audio-description for patrons with vision loss, have a person who will utilize this service share their experiences with this specific service and as a general patron of the arts. Role playing exercises demonstrating appropriate patron/staff interaction are a very useful training tool.</p> <p>Your ADA advisory board can help you plan and arrange your workshops. You can also contact your County Office for the Disabled or the ADA Technical Assistance Center (800-949-4232).</p> <p>Staff training is an important expression of an organization's ADA policy. Past and future plans for training should be included in an ADA plan.</p>

<p>7. Do you train your staff and volunteers about “person first” language and effective communication with people with disabilities?</p> <p>Who is involved in these training sessions? Check all that apply:</p> <p><input type="checkbox"/> Administrative Staff</p> <p><input type="checkbox"/> Artistic Staff</p> <p><input type="checkbox"/> Box Office Staff</p> <p><input type="checkbox"/> Ushers</p> <p><input type="checkbox"/> Volunteers</p> <p><input type="checkbox"/> Regrantees</p> <p><input type="checkbox"/> Other: _____</p>	<p><input type="checkbox"/> Yes</p> <p><input type="checkbox"/> No</p>	<p>All staff members should eliminate the word “handicapped” from their vocabulary. Staff and volunteers should familiarize themselves with accepted terminology for communicating to and about people with disabilities. Focus should always be on the person, not the disability. For example, you should avoid saying and writing, “blind patron”. Instead say or write “patron who is blind”.</p> <p><i>See Appendix pages iii - v for a fact sheet on Communicating with People with Disabilities.</i></p>
<p>8. Do you have volunteers, docents or staff specifically trained to give tours for individuals and/or groups who are disabled?</p>	<p><input type="checkbox"/> Yes</p> <p><input type="checkbox"/> No</p> <p><input type="checkbox"/> Not Applicable</p>	<p>Tours provided by trained guides will help patrons with disabilities to more fully enjoy your programmatic offerings. Even organizations that do not generally offer tours as part of their programming might provide facility tours to familiarize patrons with disabilities with the layout of the venue for future attendance.</p>
<p>EMPLOYMENT</p>		<p>Guidance</p>
<p>1. Are your employment applications and printed job information available in alternate formats (large print, Braille, audio cassette/cd, electronic) and/or do you provide reading or writing assistance upon request?</p>	<p><input type="checkbox"/> Yes</p> <p><input type="checkbox"/> No</p>	<p>Employers are required to make all aspects of the hiring process accessible to people with disabilities. Although alternate format applications and job information are preferred, common solutions for the standard application are to provide reading and/or writing assistance, or to allow the applicant to take the application home to complete it and return it later.</p>
<p>2. Have you reviewed and revised applications to avoid pre-employment inquiries about disability?</p>	<p><input type="checkbox"/> Yes</p> <p><input type="checkbox"/> No</p>	<p>It is against the law to ask a person if they have a disability prior to making a job offer. However, it is permissible to ask questions about the applicant’s ability to perform specific job functions. It is also permissible to ask the applicant to describe or demonstrate how a job function would be performed, provided that this is required of everyone applying in this job category, regardless of disability.</p> <p>It is a good idea to provide a copy of the job description (in alternate format, if needed) to the applicant.</p>

<p>3. Are those who interview candidates trained on “disability etiquette”, appropriate questions to ask, questions to avoid and how to solicit information on possible accommodations?</p>	<input type="checkbox"/> Yes <input type="checkbox"/> No	<p>Most employment discrimination against people with disabilities is not intentional. Discrimination most frequently occurs because interviewers and others involved in hiring lack knowledge about the differing capabilities of people with disabilities and make decisions based on stereotypes or unfounded fears. Training is key for providing factual information about disability, emphasizing the importance of considering people as individuals and helping interviewers feel more at ease in talking with people who have different disabilities.</p>
<p>4. Do your job descriptions accurately reflect the essential and marginal functions of the job?</p>	<input type="checkbox"/> Yes <input type="checkbox"/> No	<p>Essential functions are the fundamental duties of the position. In evaluating an essential function, you should be able to answer, “yes” to the following questions: Are all employees in the position actually required to perform the function? Would removing the function fundamentally change the job? Organizations should consider developing job descriptions not only for all paid staff, but also volunteers. If your organization is primarily supported by volunteers, it is especially prudent to have at least one general job description outlining volunteer job requirements and/or a statement on how volunteers are screened and selected.</p>
<p>5. Do appropriate personnel understand how to work with an individual to identify specific barriers to job performance and how those limitations might be overcome with reasonable accommodations?</p>	<input type="checkbox"/> Yes <input type="checkbox"/> No	<p>Utilizing a well-prepared job description reflecting essential and marginal job functions, an employer can work with an employee to find reasonable solutions to job performance barriers. Employers should discuss with the employee what accommodations they require and how best to implement them. Keep in mind that you are not required to be an expert on accommodations. The applicant is an excellent resource for ideas, as well as resources such as the Job Accommodation Network (800) 526-7234.</p> <p>Reasonable accommodations are made on a case-by-case basis. Statistics show that most reasonable accommodations cost under \$500. Example solutions are: raising a desk with bricks, volume control and TTY telephones, modifying a work or break schedule, reassigning a few marginal duties, such as photocopying or post office trips to another employee in exchange for another duty, or utilizing email instead of paper or phone transactions. Be aware that an employer is not required to lower quality or production standards to make an accommodation.</p>
<p>6. Do you provide accessible locations for hiring activities (applications, interviews)?</p>	<input type="checkbox"/> Yes <input type="checkbox"/> No	<p>If your office space is not currently accessible, it is a reasonable accommodation to hold an interview at an off-site accessible space.</p>
<p>7. Do you have a procedure for dealing with complaints from applicants or employees?</p>	<input type="checkbox"/> Yes <input type="checkbox"/> No	<p>It is suggested that organizations examine their current procedures and make sure they include a procedure for handling employment complaints relating to ADA. Some organizations may be able to utilize their ADA grievance procedure. The seriousness with which you address a complaint can help discourage frivolous suits.</p>

<p>8. Have you employed any artists with disabilities?</p>	<input type="checkbox"/> Yes <input type="checkbox"/> No	<p>Employing artists with disabilities is an important aspect of an inclusive nondiscrimination policy. Describe when and how the artist(s) participated with your arts organization in your ADA plan as support for your employment policies.</p>
<p>GRIEVANCE PROCEDURE</p>		<p>Guidance</p>
<p>Do you have a board approved Grievance procedure in place? (cfr35.107b)</p>	<input type="checkbox"/> Yes <input type="checkbox"/> No	<p>The purpose of the grievance procedure is to provide an internal mechanism for the prompt and equitable resolution of discrimination issues and complaints for employees, as well as patrons of your facility and/or programming.</p> <p>While ADA regulations do not stipulate specific standards for the grievance procedure, it is recommended that grievance procedures include the following components:</p> <ol style="list-style-type: none"> 1) A detailed description of the process for submitting a grievance. 2) A two-step review process that allows for appeal. 3) Reasonable time frames for review and resolution of the grievance 4) Clear documentation of all complaints submitted and of steps taken towards resolution. 5) Provisions for accommodating the filing of a complaint by an individual with a disability. For example, if the complainant is unable to file a written complaint, they should be able to dictate a complaint upon request. <p><i>See sample Grievance Procedures in Appendix Pages vi-viii.</i></p>
<p>2. The grievance procedure is written specifically for our organization?</p>	<input type="checkbox"/> Yes <input type="checkbox"/> No	<p>Organizations affiliated with county or state agencies or with educational entities might be able to utilize or be required to use their umbrella organization's grievance procedure. However, the NJ Arts Access Task Force has found that in most circumstances these grievance procedures do not adequately address the unique needs of the arts organization's programs or take into account the administrative structure and ADA policies of the particular arts organization. Therefore, the NJAATF recommends that such arts organizations develop their own grievance procedure, based on the procedure of the larger entity, but specific to their individual needs. Often this situation allows for a perfect opportunity to have an appeal process that moves up to the larger agency's procedure.</p>

EFFECTIVE COMMUNICATION:

PUBLICATIONS		GUIDANCE
<p>1. Do you have a publication that provides information describing your accessibility services for patrons who have disabilities? (28 CFR Sec. 35.163; 36.303)</p> <p>How do you distribute the publication? (check all that apply)</p> <p><input type="checkbox"/> General Mailing</p> <p><input type="checkbox"/> Special Mailing list</p> <p><input type="checkbox"/> Through disability related organizations</p> <p><input type="checkbox"/> Other means (please list):</p>	<p><input type="checkbox"/> Yes</p> <p><input type="checkbox"/> No</p>	<p>Many arts organizations have created an accessibility piece that describes all services and programs for patrons with disabilities. This publication can be designed to last several years by utilizing inserts listing time sensitive accessible events. Strong examples of accessibility publications can be secured by contacting organizations such as Paper Mill: The State Theatre of NJ or McCarter Theatre.</p>
<p>2. Do you include an informational statement about your accessibility and accessible programs in your routine publications and promotional materials?</p> <p>If yes, which publications?</p> <p><input type="checkbox"/> Season Brochure</p> <p><input type="checkbox"/> Newsletter</p> <p><input type="checkbox"/> Paid Advertising</p> <p><input type="checkbox"/> Printed Program/exhibit catalog</p> <p><input type="checkbox"/> Fliers/Individual invitations</p> <p><input type="checkbox"/> Website</p> <p><input type="checkbox"/> Other:</p>	<p><input type="checkbox"/> Yes</p> <p><input type="checkbox"/> No</p>	<p>Let the public know through all marketing outlets of your accessible features. For example, an appropriate statement might be:</p> <p><i>(Organization) is a wheelchair accessible space and will provide assistive services such as sign language interpreting, audio description, and open captioning upon request. An assistive listening system and large print programs are available at all times. Also, upon request, this publication can be made available in alternative formats such as Braille, Large Print, audiotape and/or computer disc.</i></p> <p>Your accessibility statement is an important aspect of providing effective communication. Include your statement in your ADA plan.</p>
<p>3. Do you use the Accessibility Symbols on publications?</p> <p>Check publications where you use the universal symbols:</p> <p><input type="checkbox"/> Programs</p> <p><input type="checkbox"/> Brochures</p> <p><input type="checkbox"/> Newsletter</p> <p><input type="checkbox"/> Fliers</p> <p><input type="checkbox"/> Paid Advertising</p> <p><input type="checkbox"/> Press releases</p> <p><input type="checkbox"/> Administrative Stationary</p> <p><input type="checkbox"/> Website</p> <p><input type="checkbox"/> Other: _____</p>	<p><input type="checkbox"/> Yes</p> <p><input type="checkbox"/> No</p>	<p>At minimum, you should include the Access Symbols in all publications and advertising. Be sure to understand the meaning of the symbols and use only the symbols that apply to your organization. The most commonly misused symbol is the wheelchair symbol. For example, organizations might include it in a brochure when their theatre space is wheelchair accessible, however they do not have an accessible bathroom. In these situations, a clarifying statement outlining the situation can be used with the symbol. Or recommend patrons call for further accessibility details.</p> <p>To acquire the access symbols, go to the website for the "Disability Access Symbols Project":</p> <p>www.gag.org/resources/das.php</p>

<p>4. Do you offer publications in Large Print?</p> <p>Check publications you offer in Large Print format and if available only upon request:</p> <p><input type="checkbox"/> Programs <input type="checkbox"/> Request only <input type="checkbox"/> Brochures <input type="checkbox"/> Request only <input type="checkbox"/> Newsletter <input type="checkbox"/> Request only <input type="checkbox"/> Fliers <input type="checkbox"/> Request only <input type="checkbox"/> Other: _____ <input type="checkbox"/></p> <p>Request only</p>	<p><input type="checkbox"/> Yes <input type="checkbox"/> No</p>	<p>Large print publications are readily achievable at low cost by enlarging documents on a copier or by enlarging on a computer. Use a 16-point type size or larger. 18 is best. The type should ideally be double-spaced and printed on a high-contrast background.</p> <p>Please note: When large print programs are provided by an organization, it is common practice to have them available <u>without advance request</u>.</p> <p>Outlining your policy and plan for providing alternate formats is an important element of a strong ADA plan.</p>
<p>5. Do you offer publications in Braille?</p> <p>Check publications you offer in Braille format and if available only upon request:</p> <p><input type="checkbox"/> Programs <input type="checkbox"/> Request only <input type="checkbox"/> Brochures <input type="checkbox"/> Request only <input type="checkbox"/> Newsletter <input type="checkbox"/> Request only <input type="checkbox"/> Fliers <input type="checkbox"/> Request only <input type="checkbox"/> Other: _____ <input type="checkbox"/></p> <p>Request only</p>	<p><input type="checkbox"/> Yes <input type="checkbox"/> No</p>	<p>Braille services can often be secured through your local Red Cross or organizations in your county that service patrons with vision loss. You may also want to contact your local Independent Living Center. For a list of centers, check the New Jersey Statewide Independent Living Council website at www.njil.org</p> <p>Also, for-profit companies such as Multimedia Transcription Services convert print into Braille and other formats for a reasonable fee. Contact 201-996-9423 or MTS.ber@hipcil.org.</p> <p>If you offer special programming for patrons with vision loss, such as audio description, it is suggested that Braille programs and some brochures be available without advance notice. Be sure to make arrangements for transcription before you offer materials in Braille.</p> <p>Outlining your policy and plan for providing alternate formats is an important element of a strong ADA plan.</p>
<p>6. Do you offer publications in audio-cassette/cd format?</p> <p>Check publications you offer in audio-cassette format and if available only upon request:</p> <p><input type="checkbox"/> Programs <input type="checkbox"/> Request only <input type="checkbox"/> Brochures <input type="checkbox"/> Request only <input type="checkbox"/> Newsletter <input type="checkbox"/> Request only <input type="checkbox"/> Fliers <input type="checkbox"/> Request only <input type="checkbox"/> Other: _____ <input type="checkbox"/></p> <p>Request only</p>	<p><input type="checkbox"/> Yes <input type="checkbox"/> No</p>	<p>Recording program materials on cassette tape is a good alternative to written information. Some people who are blind or visually impaired cannot or prefer not to read Braille or large print, and find tapes more useful. Audiocassettes can be created in-house or be recorded professionally. If you do it yourself, here are some recording tips:</p> <ul style="list-style-type: none"> • On each side of the tape, identify the side number, the document title, and the page range being read. The cassette label should include the title and tape number (i.e. Tape 1 of 4) in type and in Braille. • At the end of the recording, identify the reader. • Make sure the recording is done in a room where there is no background noise.

		<ul style="list-style-type: none"> • Read at a moderate pace and articulate words clearly. <p>Outlining your policy and plan for providing alternate formats is an important element of a strong ADA plan.</p>
<p>7. Do you offer publications in computer disc format/electronic?</p> <p>Check publications you offer in computer disc/ electronic format and if available only upon request:</p> <p><input type="checkbox"/> Programs <input type="checkbox"/> Request only <input type="checkbox"/> Brochures <input type="checkbox"/> Request only <input type="checkbox"/> Newsletter <input type="checkbox"/> Request only <input type="checkbox"/> Fliers <input type="checkbox"/> Request only <input type="checkbox"/> Other: _____ <input type="checkbox"/></p> <p>Request only</p>	<p><input type="checkbox"/> Yes <input type="checkbox"/> No</p>	<p>Computer diskettes provide an efficient, simple means of transferring print information to audible communication. Many individuals now have computers with voice output. The diskette can also be used to print out Braille text or large print. This electronic process is often the fastest way to convert print text to an accessible format. You can send discs to patrons via post or send the information electronically via e-mail.</p> <p>Outlining your policy and plan for providing alternate formats is an important element of a strong ADA plan.</p>
MARKETING/OUTREACH		
<p>1. Do you specifically market to communities of people with disabilities?</p>	<p><input type="checkbox"/> Yes <input type="checkbox"/> No</p>	<p>Outreach not only includes contacting organizations that provide support services or represent people with disabilities, but can also include senior residences and centers, independent living centers, and schools.</p> <p>Outline in your plan what outreach/target marketing you do to communities of people with disabilities and/or how you plan to expand your outreach.</p>
<p>2. Do you include on your press list the newsletters of organizations of/for people with disabilities?</p>	<p><input type="checkbox"/> Yes <input type="checkbox"/> No</p>	<p>One of the best ways to reach people with disabilities is to have a presence in the publications that they utilize as primary information sources. For example, if you are offering a program or service for patrons who are deaf or have hearing loss, you should send information to the Division for the Deaf and Hard of Hearing's newsletter, the <i>Monthly Communicator</i>, (SHHH) Self-Help for Hard of Hearing People's newsletter, and Hand's On monthly calendar.</p>
<p>3. Do you include a statement or paragraph about your physical accessibility and accessible programming in your press releases?</p>	<p><input type="checkbox"/> Yes <input type="checkbox"/> No</p>	<p>Similar to including a standard paragraph recognizing funders in all press releases, it is also recommended to include an accessibility statement. If you are offering a specific accessible program or service, be sure to send a separate release and/or highlight it in other releases.</p>
<p>4. Are there signs in your reception area and general public receiving area indicating the availability of materials in alternate formats and/or other accessible services?</p>	<p><input type="checkbox"/> Yes <input type="checkbox"/> No</p>	<p>People will not use your accessible services if they do not know about them. Not only do ADA Guidelines <u>require</u> signage advertising accessible services, but also prominent signage educates the general public that frequents your facility. Statistically, a majority of patrons will need accessible services at some point and/or have a friend or family member who can use</p>

		<p>them. Even companies that do not have their own venue can have signage publicizing available services at individual performances.</p> <p>Another way to let patrons know about your services is to present them as routine policy. For example, ushers can offer a choice of a large print or standard program to every patron. Have your assistive listening devices prominently displayed in the lobby.</p>
<p>5. Do you include accessibility information on your website?</p>	<input type="checkbox"/> Yes <input type="checkbox"/> No <input type="checkbox"/> Not Applicable	<p>Your website is an important avenue to market your accessibility. With new advancements in technology, people with disabilities are utilizing computers more frequently to access information. Make accessibility a prominent feature on your homepage.</p>
<p>6. Do you offer discounted admission for patrons who are disabled?</p>	<input type="checkbox"/> Yes <input type="checkbox"/> No	<p>ADA does not require that an organization provide discounted ticket prices to a patron with a disability. However, organizations often offer a discount as an encouragement to build an audience for a specific service such as audio described or sign language interpreted programs. Some people with disabilities are on a fixed income and have not developed a tradition of attending the arts because cultural events were not previously accessible. Like any new audience you are trying to cultivate, discounted tickets are an added incentive.</p> <p>It is important to note, <u>an organization cannot request a patron to provide proof of a disability.</u></p>
<p>7. Do you have an admissions policy for support people accompanying persons with disabilities (companions, personal assistants, etc.)?</p>	<input type="checkbox"/> Yes <input type="checkbox"/> No	<p>Because most patrons want to attend events with a companion, and some patrons with disabilities require assistance, most organizations extend the discounted price to a companion as well. Please note, the ADA provides guidelines that mandate companion seating availability for patrons with disabilities, but does not require discounted tickets.</p> <p>An organization should clearly outline their ticketing policy with staff to ensure consistency in customer service, as well as to build outreach efforts.</p> <p>Inclusion of this policy in your ADA plan further defines your management and marketing ADA policies.</p>
<p>8. Do you discount workshop or class fees for patrons/students who are disabled?</p>	<input type="checkbox"/> Yes <input type="checkbox"/> No	<p>Many organizations have expanded their current discounts or scholarships to include people with disabilities. This type of outreach policy demonstrates an inclusionary attitude.</p>
<p>9. Do you adapt strategies and utilize alternative methods for conveying program content and information on your organization to individuals with learning and developmental disabilities, mental illness, brain injuries, and other</p>	<input type="checkbox"/> Yes <input type="checkbox"/> No	<p>Staff should be trained to adapt communication strategies to meet the individual needs of current and prospective patrons, employees, volunteers, and others. If you offer educational programming, staff should be prepared to meet the individual needs of participants with disabilities and to accommodate varying learning styles.</p>

individuals who may require this service?		
WEBSITES	<p>As our society increasingly depends on the convenience of the Internet as a vehicle for programs, goods or services, the more it is important that accessible web design be addressed. Accessible web design enables effective communication and saves resources since documents can be readily available and fulfill many requests for alternate formats.</p> <p>For complete guidelines, list of priorities and a checklist go to www.w3.org/WAI or check IBM's checklist for a more user friendly definition of website accessibility: www-3.ibm.com/able/accessweb</p> <p>The guidelines can be complex for the layperson and you will most likely need to work with a computer/website expert. The following questions address some of the general considerations. This list is by no means complete.</p>	
1. Does your website provide a text equivalent for every non-text element (e.g. via "Alt", "longdesc" or in element content)?	<input type="checkbox"/> Yes <input type="checkbox"/> No	This includes images, graphical representations of text, image map regions, images used as list bullets, spacers, graphical buttons, ascii art, and frames.
2. Does your website employ alternative text features to describe images and graphics?	<input type="checkbox"/> Yes <input type="checkbox"/> No	Some web users may not be able to see images, others use text-based browsers that do not support images. When the mouse or arrow rolls over an image, text explaining the graphic or image will appear. This is a basic and simple feature to incorporate into your site.
3. Does your website allow the user to configure the foreground and/or background color of all text, with an option to override author-specified, and user agent default, foreground colors?	<input type="checkbox"/> Yes <input type="checkbox"/> No	Allow the user to select from among the range of system colors. Choose colors carefully. Text and colored backgrounds (or background images) should contrast comfortably for reading. If you can set your monitor to grayscale and still read the text, it is probably ok.
4. Does your website summarize the content of each graph and chart, or use the longdesc attribute to link to the description or data?	<input type="checkbox"/> Yes <input type="checkbox"/> No <input type="checkbox"/> Not Applicable	A chart or graph is essentially an image with detailed information. Some charts or graphs have more information and data in them than others. Text browsers and screen readers cannot convey images to their users, so an equivalent alternative to the essential information that is visually available from the chart or graph must be provided. The amount of alternative information to provide depends on the contextual use of the chart or graph, but generally it should include all the information available to the sighted user.

<p>5. Are your Web pages readable without requiring style sheets?</p>	<input type="checkbox"/> Yes <input type="checkbox"/> No	<p>Cascading Style Sheets (CSS) describe how elements within a Web page are presented. A different style sheet can be used to control how a document page is presented on displays, in print, or perhaps how the page is pronounced or Brailled. A style sheet is an elegantly designed yet simple mechanism for adding styles, such as fonts, colors, and spacing to Web documents. However, not all style sheet presentation features can be rendered satisfactorily with older browsers. Because CSS is not supported by all browsers and assistive technology, it is important that Web pages be readable without requiring style she</p>
<p>6. Does your website provide captions or transcripts of important audio content and/or provide transcripts or audio descriptions of important video content?</p>	<input type="checkbox"/> Yes <input type="checkbox"/> No <input type="checkbox"/> Not Applicable	<p>For those who are deaf or hard of hearing, audio content is not accessible. Videos without descriptions are not accessible to the blind. In both cases, the information needs to be provided in an alternative format. These alternative formats are also used frequently by those who have hardware or environmental limitations. For example, the captions on a video can be selected when the audio would be distracting to others in the area or the area is too noisy to hear the audio.</p> <p>The National Braille Association (NBA) has published a Tape Recording Manual, which gives instructions to readers on how to describe complex pictures when recording material for use by blind individuals. The World Wide Web Consortium has made available an excerpt from the NBA Tape Recording Manual to assist Web authors who are trying to describe complex images on their Web sites. It can also be used to describe complex images in documentation.</p>
<p>7. Does your website provide links that make sense?</p>	<input type="checkbox"/> Yes <input type="checkbox"/> No	<p>Use phrases that tell visitors exactly what to expect when they “click here,” even if the link and a graphic are redundant. Make the clickable text obvious, especially if it is embedded in other text.</p>
<p>8. If accessibility cannot be accomplished in any other way, do you provide a text-only page with equivalent information or functionality?</p>	<input type="checkbox"/> Yes <input type="checkbox"/> No <input type="checkbox"/> Not Applicable	<p>If you find that compliance cannot be achieved any other way, a text-only page with equivalent information and functionality should be provided to make the Web site accessible. However, this is not the ideal solution. The text-only pages must be maintained and updated in congruence with the primary Web pages. Update the content of the text-only page whenever the primary page changes.</p>

<p>9. Is your website “Bobby” approved or screened by Accessibility-Prompt software?</p>	<input type="checkbox"/> Yes <input type="checkbox"/> No	<p>Bobby is a free validation tool created by the Center for Applied Special Technology (CAST). Bobby will evaluate your page or site for compliance with various browsers, versions of HTML, and accessibility standards. It helps identify changes to pages needed so users with disabilities can more easily use a site. Their website is: www.cast.org/bobby. There are some fees after the first screening.</p>
<p>MEETINGS ADA 28 CFR 35149, 160, 161, 303,308)</p>		<p>This section applies to meetings, lectures, symposia, conferences, etc. open to the public.</p>
<p>1. Is care taken to assure that people with disabilities are represented at meetings?</p> <p>Check which apply: <input type="checkbox"/> As speakers? <input type="checkbox"/> As panelists? <input type="checkbox"/> As artists? <input type="checkbox"/> As participants?</p>	<input type="checkbox"/> Yes <input type="checkbox"/> No <input type="checkbox"/> Not Applicable	<p>This information can be included in your ADA under policy, practices and procedure section.</p>
<p>2. Does pre-meeting information (e.g. letters, registration materials, and/or program brochures) contain necessary information for people with disabilities to respond to the invitation and indicate need for accommodations?</p> <p>Check which apply: <input type="checkbox"/> TTY phone number where other numbers are listed or relay number <input type="checkbox"/> Print material availability in alternate formats <input type="checkbox"/> Means to request assistive services, such as assistive listening equipment.</p>	<input type="checkbox"/> Yes <input type="checkbox"/> No <input type="checkbox"/> Not Applicable	

PROGRAMS AND SERVICES

Fill out all sections that relate to your organization's primary and secondary offerings. Even if you do not own your space or are a touring company, the majority of the following questions will apply to your work and should be discussed with your contact at the performance venues to define who will be responsible for each aspect of compliance and/or accommodation request.

PERFORMING ARTS EVENTS (Theatre, Dance, Music, etc.)

If you are a primarily a museum or other non-performance art venue, yet offer some performance events, you need to fill out this section for your performance-related programming.

List all the services, programs and accommodations you currently offer and plan to offer in your ADA plan.

1. Do you offer advance copies of scripts or programming synopses to people with hearing impairments, vision loss or cognitive disabilities?

- Yes
 No

Please note, people with vision loss might require an alternate format such as large print, audiotape/cd, Braille or computer disc. Also note, scripts are not considered a substitute for other services such as captioning, Assistive Listening Devices, or Interpreters for people with hearing loss.

2. Are assistive listening devices available? (ADAAG 4.1.3[19]b)
If yes, check off the type of system below:

- Infrared
 FM
 Induction-loop

- Yes
 No

Systems are required for spaces with over 50 fixed seats or have an audio amplification system. The Access Board is currently reviewing the recommendation that systems should be provided for spaces with non-fixed seating as well. Currently, the law states "Fixed Seating". Two types of receivers are required: neck loops for use with hearing aids and cochlear implants, and headsets for use directly into the ear.

An assistive listening system amplifies sound and transmits it to a person's hearing aid or a receiver worn by the patron. In addition, it can be used to transmit audio description for patrons with vision loss. The minimum number of receivers should be equal to 4% of the total number of seats, but no less than two receivers. (ADAAG 4.1.3[19]b)

Companies that do not own their own space should check to see if venue has assistive listening devices.

The Kennedy Center has an informative guide for Performing Arts Settings called: *Assistive Listening Devices for People with Hearing Loss* that the NJAATF can email you upon request.

3. Do you offer sign language interpreted performances?

- Yes
 No

To find a listing of sign-interpreters for meetings, lectures and theatrical events contact the Division of the Deaf and Hard of Hearing at 1-800-792-8339. There is also a list of theatrical interpreters in the NJ Arts Access

If Yes, check appropriate box:

<input type="checkbox"/> Upon request only How much advance notice do you require? <hr/> <input type="checkbox"/> Offer 1 or more scheduled performances per production run <input type="checkbox"/> Offer select performances throughout the season		<p>Task Force Resource Notebook available via your local County Arts Agency or the Arts Access Task Force.</p> <p>The NJAATF Resource notebook also contains sample contracts for sign-language interpreters.</p> <p>It is reasonable to request a minimum of 2-4 weeks notice for events that are not scheduled to be interpreted.</p> <p>Due to New Jersey's proximity to New York City and access to Broadway interpreters, fees for theatrical interpreters can range from \$250 to \$1,500, depending on the interpreter's experience.</p>
<p>4. Do you offer sign-interpretation for lectures or tours held in conjunction with your productions?</p> <p>If Yes, check appropriate box:</p> <input type="checkbox"/> Upon request only How much advance notice do you require? <hr/> <input type="checkbox"/> Offer select interpreted lectures or tours throughout the season	<input type="checkbox"/> Yes <input type="checkbox"/> No <input type="checkbox"/> Not Applicable	<p>People who are deaf or hard of hearing often request interpreters or transliterators in order to participate in conversations, meetings, and events. Interpreters translate from spoken language to American Sign Language (ASL) and vice versa. Translitterators interpret from spoken English to Pidgin Signed English, Manually Coded English, or Cued Speech, and vice versa. The person who is deaf or hard of hearing should be consulted as to his or her preferred type of interpreting.</p> <p>Fees for interpreters generally range from \$25-\$35 an hour with a two-hour minimum fee. In order to assure the availability of an interpreter, be sure to make your request as soon as your event is scheduled.</p>
<p>5. Have you established a suitable location for a sign interpreter so that patrons who are deaf can see the performances as well as their interpreters?</p>	<input type="checkbox"/> Yes <input type="checkbox"/> No <input type="checkbox"/> Not Applicable	<p>Prior to releasing seats for sale, work with the interpreter and an artistic representative of the show to decide on the best location for the interpreter. It is imperative that the patrons watching the interpretation can view the interpreter and the performance within the same line of vision.</p>
<p>6. Have you established a suitable seating location for patrons who use a wheelchair and also need the services of an interpreter?</p>	<input type="checkbox"/> Yes <input type="checkbox"/> No <input type="checkbox"/> Not Applicable	<p>Be aware, that some patrons may require more than one service.</p>
<p>7. Do you offer open captioned performances?</p> <p>If Yes, check appropriate box:</p> <input type="checkbox"/> Upon request only: How much advance notice do you require? <hr/> <input type="checkbox"/> Offer 1 or more scheduled performances per production run	<input type="checkbox"/> Yes <input type="checkbox"/> No	<p>Open captioning is available to patrons with hearing loss who do not fully benefit from assistive listening devices or American Sign Language (ASL). The dialogue of the performance or lecture appears on a large digital screen as the action of the play or lecture occurs on stage.</p>

<input type="checkbox"/> Offer select performances throughout the season		
8. Have you established a suitable location for the captioning screen so that patrons with hearing loss can see the performances as well as the captioning?	<input type="checkbox"/> Yes <input type="checkbox"/> No <input type="checkbox"/> Not Applicable	It is imperative that patrons watching the captions can view the captions and the performance within same line of vision.
9. Have you established a suitable seating location for patrons who are using the open captioning services?	<input type="checkbox"/> Yes <input type="checkbox"/> No <input type="checkbox"/> Not Applicable	Be certain that the box office holds seats in the section where patrons can best view the captioning. Each organization will have to determine a clear policy for release of these seats. While ticketing policies are currently being debated and fine-tuned in arts organizations across the country, the basic rule of thumb is to hold a reasonable proportion of seats as long as possible, preferably until curtain.
10. Have you established a suitable seating location for patrons who use a wheelchair and also need the captioning services?	<input type="checkbox"/> Yes <input type="checkbox"/> No <input type="checkbox"/> Not Applicable	Be aware, that some patrons may require more than one service.
11. Do you offer audio-described performances? If Yes, check appropriate box: <input type="checkbox"/> Upon request only How much advance notice to you require? _____ <input type="checkbox"/> Offer 1 or more scheduled performances per scheduled run <input type="checkbox"/> Offer select performances throughout the season	<input type="checkbox"/> Yes <input type="checkbox"/> No <input type="checkbox"/> Other	Audio described performances provide patrons with vision loss with an earpiece and transistor through which they can hear a live, objective and concise description of the action on stage in between dialogue and music.
12. Have you established a suitable seating location for patrons who are using the audio description services?	<input type="checkbox"/> Yes <input type="checkbox"/> No <input type="checkbox"/> Not Applicable	Since many patrons who will use the audio description services have some vision, it is recommended to hold seats close to the stage/performance. The seating should offer the most safe and direct path of travel, avoiding multiple stairs, especially those without adequate handrails. Some seats should also be able to accommodate service animals.
13. Have you established a suitable seating location for patrons who use a wheelchair and also need the audio description services?	<input type="checkbox"/> Yes <input type="checkbox"/> No <input type="checkbox"/> Not Applicable	Be aware, that some patrons may require more than one service.
14. Do you offer pre-performance sensory seminars for patrons	<input type="checkbox"/> Yes <input type="checkbox"/> No	Sensory seminars are pre-show hands-on sessions where patrons with vision loss have an opportunity to

<p>with vision loss?</p> <p>If Yes, check appropriate box:</p> <p><input type="checkbox"/> Upon request only: How much advance notice to you require?</p> <p>_____</p> <p><input type="checkbox"/> Offer 1 or more scheduled sensory seminar per production run</p> <p><input type="checkbox"/> Offer sensory seminars for select performances throughout the season</p>		<p>feel props, set pieces and costumes from a production in order to achieve a better understanding of the critical visual production elements.</p>
<p>15. Do you have accessible seats that can accommodate service animals?</p>	<p><input type="checkbox"/> Yes <input type="checkbox"/> No</p>	<p>People are most familiar with “seeing eye” dogs. However, service animals also assist patrons who are deaf and patrons with mobility impairment. While there are no specifics outlined for amount of space required, it is wise to consider where service dogs might best be accommodated. Soliciting input from someone who uses a service animal would be a practical action step.</p>
<p>16. Is your front of house staff aware of how to work with service animals?</p>	<p><input type="checkbox"/> Yes <input type="checkbox"/> No</p>	<p>Box office and house staff need to be aware that service animals cannot be denied access and should never be taken from their owner. Furthermore, all staff should be informed that they should not pet the animal. They are working animals and should not be distracted from their job.</p>
<p>VISUAL ARTS/ MUSEUMS</p>		<p>GUIDANCE</p> <p>If you are primarily a performing arts organization, yet also offer some exhibits, you need to fill out this section for your exhibit-related programming.</p> <p>The Smithsonian Institute has terrific ADA guidelines for Accessible Exhibition Design. Visit www.si.edu/opa/accessibility/exdesign. Also strongly recommended: <i>Everyone’s Welcome: The Americans with Disabilities Act and Museums</i>, a publication of the American Association of Museums. Visit their website: www.aam-us.org.</p> <p>Clearly outline and provide dates for services, programming and accommodations that you offer, have offered or plan to offer in your ADA plan.</p>
<p>1. Do you offer Tactile Exhibits?</p> <p>If Yes, check off most appropriate:</p> <p><input type="checkbox"/> These features are offered for all exhibits</p> <p><input type="checkbox"/> Offered for select exhibits</p>	<p><input type="checkbox"/> Yes <input type="checkbox"/> No</p>	<p>Tactile exhibits are displays or portions of exhibits that can be touched by patrons.</p>

<p>2. Do you offer small models of large exhibits?</p> <p>If Yes, check off most appropriate:</p> <p><input type="checkbox"/> These features are offered for all exhibits</p> <p><input type="checkbox"/> Offered for select exhibits</p>	<p><input type="checkbox"/> Yes <input type="checkbox"/> No</p>	
<p>3. Do you offer video taped versions of exhibits in areas that are not currently accessible to people with physical impairments?</p>	<p><input type="checkbox"/> Yes <input type="checkbox"/> No</p>	<p>When physical access to an exhibit is impossible an organization can offer a video taped tour of the exhibit as a reasonable accommodation.</p>
<p>4. Are video presentations captioned?</p>	<p><input type="checkbox"/> Yes <input type="checkbox"/> No <input type="checkbox"/> Not Applicable</p>	<p>Videos can be easily captioned, though it is more economical if they are captioned during the initial production process. There are companies that provide this service.</p>
<p>5. Do you offer printed self-guiding tours, and/or self-guiding explanatory signage in your exhibit areas?</p>	<p><input type="checkbox"/> Yes <input type="checkbox"/> No</p>	<p>Printed self-guiding tours are an excellent way for people who cannot hear a tour guide/docent to enjoy your facility.</p>
<p>6. Do you have volunteers, docents or staff specifically trained to give tours with individuals and/or groups who are disabled?</p>	<p><input type="checkbox"/> Yes <input type="checkbox"/> No</p>	<p>Note that Assistive Listening Devices and self-guided printed tours are essential for patrons with hearing loss. Interpreters should be an option for Deaf patrons who request them.</p>
<p>7. Do you offer audiotape cassettes/cds describing exhibits?</p> <p>If Yes, check off most appropriate:</p> <p><input type="checkbox"/> Audio tapes/cds are offered for all exhibits</p> <p><input type="checkbox"/> Audio tapes/cds are offered for select exhibits</p> <p><input type="checkbox"/> Upon request only How much advance notice to you require?</p> <p>_____</p>	<p><input type="checkbox"/> Yes <input type="checkbox"/> No</p>	<p>In lieu of having a live describer/docent, many visual arts organizations provide audio taped tours that provide detailed, objective descriptions of exhibits, which can be utilized by patrons with vision loss and other disabilities.</p>
<p>8. Do you offer sign-interpreted tours?</p>	<p><input type="checkbox"/> Yes <input type="checkbox"/> No <input type="checkbox"/> Not</p>	<p>Organizations that offer tours should be able to offer alternate forms of communication for patrons with disabilities.</p>

<p>If Yes, check off most appropriate: <input type="checkbox"/> These features are offered for all exhibits</p> <p><input type="checkbox"/> Offered for select exhibits</p> <p><input type="checkbox"/> Upon request only How much advance notice to you require? _____</p>	<p>Applicable</p>	
<p>9. Do you offer sign interpretation for lectures held in conjunction with your exhibits?</p> <p>If Yes, check off most appropriate:</p> <p><input type="checkbox"/> Upon request only How much advance notice to you require? _____</p> <p><input type="checkbox"/> always</p> <p><input type="checkbox"/> Offered for select lectures</p>	<p><input type="checkbox"/> Yes <input type="checkbox"/> No <input type="checkbox"/> Not Applicable</p>	<p>Organizations that offer lectures should be able to offer assistive services for patrons with disabilities.</p>
<p>10. Do you offer real-time (CART) captioning for lectures held in conjunction with your exhibits?</p> <p>If Yes, check off most appropriate:</p> <p><input type="checkbox"/> Upon request only How much advance notice to you require? _____</p> <p><input type="checkbox"/> always</p> <p><input type="checkbox"/> Offered for select lectures</p>	<p><input type="checkbox"/> Yes <input type="checkbox"/> No</p>	<p>Real-time captioning benefits general audiences as well since it is visible to all. It is important to publicize this service in advance marketing materials since many people are not aware of captioning services.</p>
<p>11. Do you offer portable FM assistive listening devices for tours?</p> <p>If Yes, check off most appropriate:</p> <p><input type="checkbox"/> Upon request only How much advance notice to you require? _____</p> <p><input type="checkbox"/> always</p>	<p><input type="checkbox"/> Yes <input type="checkbox"/> No</p>	<p>These wireless devices can be used with or without hearing aids. They are also useful for all patrons and docents in galleries with poor acoustics. It is important to have signs indicating that these devices are available otherwise people with hearing loss will not know to ask for them.</p>

TRANSPORTATION	<p>Items in the following Transportation section are not a requirement of the law, but offer guidance on how your organization might utilize resources to make programs and services more readily available to patrons with disabilities. Transportation is one of the primary barriers to attending cultural events for patrons with disabilities. Access to convenient public transportation can alleviate this problem for many patrons and allow for independent access with dignity.</p>	
1. Is your facility on a public transportation route?	<input type="checkbox"/> Yes <input type="checkbox"/> No <input type="checkbox"/> Not Applicable	<p>Be sure to check to see if public transportation is available during the hours of your program's operation.</p>
2. Do you advertise public access routes to your facility/events/programs?	<input type="checkbox"/> Yes <input type="checkbox"/> No <input type="checkbox"/> Not Applicable	<p>If your facility is near safe, convenient access to public transportation, make sure to communicate this information via publications and box office staff.</p> <p>This information not only assists patrons with disabilities, but all people who need transportation assistance. This is an example of how ADA consideration can universally benefit all your patrons.</p>
3. If you help coordinate shuttle service to accessible bus sites, parking lots or train stations, is the shuttle service provided in accessible vehicles?	<input type="checkbox"/> Yes <input type="checkbox"/> No <input type="checkbox"/> Not Applicable	<p>It is important that your shuttle service driver/staff is trained to provide assistance to patrons with disabilities.</p>
4. Do you offer or coordinate a transportation service to get patrons to your facility/events/programs?	<input type="checkbox"/> Yes <input type="checkbox"/> No <input type="checkbox"/> Not Applicable	<p>Some organizations have developed a relationship with county-funded Para-transit organizations to provide special after-hours transportation to and from cultural events for patrons with disabilities.</p> <p>Senior centers and residencies often have a jitney service. Arranging transportation and promoting your assistive services, can bring in patrons who wouldn't otherwise attend.</p>

TOURING AND/OR EDUCATION COMPANIES

<p>1. Do you have a clear understanding of your ADA responsibilities as a touring company?</p>	<input type="checkbox"/> Yes <input type="checkbox"/> No	<p>Touring companies are those organizations that present their products or services, i.e. performances or exhibits, in facilities other than their own home base. Whether touring to one or 101 venues, the touring company has the obligation to perform in accessible venues (see page 31, question 5 for further guidance regarding touring and facility use) and shares the responsibility for providing programmatic access. The touring company should have a conversation with each perspective venue before agreeing to produce their performance/exhibit there. This conversation should outline the elements of accessibility that each party is willing to supply. For example, does the facility have an assistive listening system, who will provide sign interpretation should that service be requested, who will provide programs in large print format, etc.? These items should be made part of the contract.</p>
<p>2. Do you have a mechanism to determine if the spaces you perform in and/or hold workshops are ADA compliant?</p>	<input type="checkbox"/> Yes <input type="checkbox"/> No	<p>How do you determine if a venue is compliant? Do you have an accessibility checklist that the venue is required to complete? Does a road manager complete an on-site accessibility survey for each performance venue? (This would be helpful to create a database of compliant spaces.)</p> <p>REMINDER: ADA compliance does not only mean wheelchair accessibility. Assistive Listening Systems are required in facilities with over 50 fixed seats or that have an audio amplification system to be ADA compliant.</p> <p>A strong ADA plan will include a copy of the mechanism used.</p> <p><i>See Appendix Page ix for a sample Contract Rider for Touring Companies.</i></p>
<p>3. Does your contract for service include a statement regarding access and/or an ADA compliance rider?</p>	<input type="checkbox"/> Yes <input type="checkbox"/> No	<p>If you do not currently have a statement in your contract, it is suggested that you include a statement such as:</p> <p><i>ORGANIZATION has a strong commitment to performing only in spaces that comply with the requirements of the Americans with Disabilities Act. ORGANIZATION requests that each presenter of ORGANIZATION demonstrate a good faith effort towards compliance with regard to their facility and services. As part of our contractual agreement we require completion of the attached ADA Compliance Rider. For questions regarding accessibility and our programs, please call XX, ORGANIZATION'S ADA coordinator at XX.</i></p> <p>OR</p> <p><i>The contractor (arts venue name) and the agency (your</i></p>

		<p><i>agency's name) do hereby agree that the provisions of Title II of the Americans with Disabilities Act of 1990 (the "Act") (42 U.S.C. 12101 ET SEQ.), which prohibits discrimination on the basis of disability by public entities in all services, programs and activities provided or made available by public entities, and the rules and regulations promulgated pursuant thereunto, are made a part of this contract. The contractor further agrees to conduct all activities in compliance with the provisions of Title VI of the Civil Rights Act of 1964, the Rehabilitation Act of 1973, the Age Discrimination Act of 1975, Title IX of the Education Amendments of 1972, and the U.S. Department of Labor's regulations at 29 CFR, Parts 31, 32, and 34.</i></p> <p>If yes, it is advisable to include the statement and ADA Compliance Rider in your ADA plan.</p>
<p>4. Do you keep an ongoing record of compliance of performance and workshop venues that you visit?</p>	<input type="checkbox"/> Yes <input type="checkbox"/> No	<p>Since most companies keep a report or record of all venues they tour to, it is highly recommended venue accessibility be incorporated into this history.</p>
<p>5. Do you offer sensitivity training to your staff, teaching artists, performers and/or traveling production crew?</p>	<input type="checkbox"/> Yes <input type="checkbox"/> No	<p>Include training of artistic staff in the policy section of your ADA plan.</p>
<p>6. Have you toured your programming to senior residences or centers, and disability-related organizations or schools?</p>	<input type="checkbox"/> Yes <input type="checkbox"/> No	<p>Include performances held specifically for patrons with disabilities in your ADA plan.</p>
<p>7. Do you offer study guides and pre-workshop/performance materials in alternate formats?</p> <p>If yes, what formats:</p> <input type="checkbox"/> Large Print <input type="checkbox"/> Braille <input type="checkbox"/> Audio tape/cd <input type="checkbox"/> Computer Disc	<input type="checkbox"/> Yes <input type="checkbox"/> No <input type="checkbox"/> Not Applicable	

COUNTY ARTS AGENCIES

GUIDANCE

<p>1. Do you have an ADA compliance requirement for your grantees application or contract process?</p>	<input type="checkbox"/> Yes <input type="checkbox"/> No	<p>Be sure to outline your requirement in your ADA plan, as well as how it is implemented and monitored.</p>
<p>2. Do you have an assessment tool that you utilize to determine grantees' ADA compliance?</p>	<input type="checkbox"/> Yes <input type="checkbox"/> No <input type="checkbox"/> Other	<p>If yes, a copy of the assessment tool should be an appendix to your ADA Plan.</p>

3. Do you provide grantees with a self-assessment tool so they can determine their ADA Compliance?	<input type="checkbox"/> Yes <input type="checkbox"/> No	Providing grantees with ADA information and the tools required to assess their accessibility will facilitate compliance efforts.
4. Do you hold all public programming and meetings in compliant spaces?	<input type="checkbox"/> Yes <input type="checkbox"/> No	Explain how you assess each space's compliance in your ADA plan.
5. Do you offer ADA training workshops for outside groups? If Yes, check off which groups you offer workshops to: <input type="checkbox"/> grantees <input type="checkbox"/> grant applicants <input type="checkbox"/> other county arts agencies <input type="checkbox"/> other _____	<input type="checkbox"/> Yes <input type="checkbox"/> No <input type="checkbox"/> Other	Provide a brief description of the workshops in your ADA plan.
6. Is the grievance procedure separate from the county's procedure?	<input type="checkbox"/> Yes <input type="checkbox"/> No	When feasible, include the County procedure along with your own procedure in a complete ADA plan. <i>(See above section on grievance procedures page 11)</i>

PART TWO

FACILITY INTRODUCTION AND ASSESSMENT QUESTIONS

The Americans With Disabilities Act (ADA) requires that a public accommodation remove architectural barriers in existing facilities, where such removal is readily achievable, i.e. easily accomplished and able to be carried out without undo difficulty or expense. Where a public accommodation can demonstrate that barrier removal is not readily achievable, the public accommodation must still make its goods, services, facilities, privileges, advantages, or accommodations available through alternative methods.

Examples of alternatives and reasonable accommodations to barrier removal might include:

- 1) Box office staff can come to the patron with a clipboard-writing surface to complete the transaction where a box office counter is too high.
- 2) A videotaped tour of an inaccessible second level gallery that can be viewed on the first floor.
- 3) Relocating activities to accessible locations.

A public accommodation is urged to take measures to comply with the barrier removal requirements in accordance with the following order of priorities.

(Priority 1) First, a public accommodation should take measures to provide access to a place of public accommodation from public sidewalks, parking, or public transportation. For example, these measures include installing an entrance ramp, widening entrances, and providing accessible parking spaces.

(Priority 2) Second, a public accommodation should take measures to provide access to those areas of a place of public accommodation where goods and services are made available to the public. For example, these measures include adjusting the layout of exhibits, rearranging tables, providing Brailled and raised character signage, widening doors, providing visual alarms, and installing ramps.

(Priority 3) Third, a public accommodation should take measures to provide access to restroom facilities. For example, these measures include removal of obstructing furniture or vending machines, widening of doors, installation of ramps, providing accessible signage, widening of toilet stalls, and installation of grab bars.

(Priority 4) Fourth, a public accommodation should take any other measures necessary to provide access to the goods, services, facilities, privileges, advantages, or accommodations of a place of public accommodation.

PART TWO

FACILITY IN WHICH YOU HOLD YOUR PROGRAMMING

Complete the following section about the facility(s) in which you hold your programming. Please note: the facility section relates to your public spaces, and therefore does not relate to your administrative spaces.

<p>1. Do you OWN the facility(s) where you hold your programming and/or administer the primary function of your organization?</p> <p>If yes, list the venues below. You need to complete the Facility/Physical Accessibility sections for <u>each</u> venue you own.</p> <hr/> <hr/>	<p><input type="checkbox"/> Yes <input type="checkbox"/> No</p>	<p>If you own your facility you must complete all categories of this survey that relate to your facility. Be sure to fill all sections that relate to your work.</p>
<p>2. Do you LEASE the facility where you hold your programming and/or administer the primary function of your organization?</p> <p>If yes, list the venues below. You need to complete the Facility/Physical Accessibility sections for <u>each</u> venue you lease. Put a check in the <input type="checkbox"/> box if the venue has an up to date ADA plan.</p> <p><input type="checkbox"/></p> <hr/> <p><input type="checkbox"/></p> <hr/> <p><input type="checkbox"/></p> <hr/> <p><input type="checkbox"/></p> <hr/>	<p><input type="checkbox"/> Yes <input type="checkbox"/> No</p>	<p>When you lease a space, the responsibility for accessibility lies with both you and the landlord. Usually, responsibility can be determined by the lease agreements and the identification of which elements are “common areas” (e.g. parking lot, common area restrooms) and which areas are under the control of the tenant.</p> <p>It is your responsibility to make sure that you are presenting in an accessible space! Contact the leasing agent to see if they have done an ADA assessment of the facility. Request a copy for your files. If the assessment reveals areas of non-compliance, ask for their plan to comply and/or work with your landlord to develop a plan that outlines responsibilities to accomplish compliance.</p>
<p>3. Do you RENT the facility where you hold your programming and/or administer the primary function of your organization?</p> <p>If yes, list the venues below. You need to complete the Facility/Physical Accessibility sections for <u>each</u> venue you rent. Put a check in the <input type="checkbox"/> box if the venue has an up to date ADA plan.</p> <p><input type="checkbox"/></p> <hr/> <p><input type="checkbox"/></p> <hr/> <p><input type="checkbox"/></p> <hr/> <p><input type="checkbox"/></p> <hr/>	<p><input type="checkbox"/> Yes <input type="checkbox"/> No</p>	<p>It is your responsibility to make sure that you are presenting in an accessible space!</p> <p>Even if you are renting a facility, ADA regulations still apply. Contact the organization you are renting to see if they have done an ADA assessment of their facility. Request a copy for your files and to confirm the accessibility for your performance. If they have not done an assessment, offer to facilitate their process by providing them with a copy of this self-assessment or complete the assessment yourself. If the assessment reveals major areas of non-compliance, ask for their plan to achieve compliance. If they do not plan to be in compliance within a short time frame, it is recommended that you look for another space that is compliant as soon as possible!</p>

<p>4. Do you BORROW the facility where you hold your programming and/or administer the primary function of your organization?</p> <p>If yes, list the venues below. You need to complete othe Facility/Physical Accessibility sections for <u>each</u> venue you borrow to assess the overall accessibility of your performance venue. Put a check in the <input type="checkbox"/> box if the venue has an up to date ADA plan.</p> <p><input type="checkbox"/></p> <hr/> <p><input type="checkbox"/></p> <hr/> <p><input type="checkbox"/></p> <hr/> <p><input type="checkbox"/></p> <hr/>	<p><input type="checkbox"/> Yes <input type="checkbox"/> No <input type="checkbox"/> Other</p>	<p>Even if you do not pay a rental fee for your usage of a facility, ADA regulations still apply. It is your responsibility to make sure that you are presenting in an accessible space! Contact the organization you borrow from to see if they have done an ADA assessment of their facility. If they have, get a copy for your files and confirm the accessibility of your performance. If they have not done an assessment, offer to facilitate their process by providing them with a copy of this self-assessment. If they have done an assessment and have major areas of non-compliance, ask for their plan to comply. If they do not plan to be in compliance within a short time frame, it is recommended that you look for another space that is compliant!</p> <p>Use caution when borrowing church facilities. While churches that only serve their congregation do not need to comply with ADA <u>your program does need to comply.</u></p>
<p>5. Do you tour your programming to multiple venues?</p> <p>How many venues do you tour to? ____#</p> <p>If you tour to <u>four</u> or less venues, please list them below. You should obtain access information on all listed venues. Put a check in the <input type="checkbox"/> box if the venue has an up to date ADA plan.</p> <p><input type="checkbox"/></p> <hr/> <p><input type="checkbox"/></p> <hr/> <p><input type="checkbox"/></p> <hr/> <p><input type="checkbox"/></p> <hr/>	<p><input type="checkbox"/> Yes <input type="checkbox"/> No</p>	<p>Many organizations perform <u>annually</u> at major NJ venues as well as tour to a multitude of national venues. While ADA does not specifically define “touring company”, it makes clear that such entities are still responsible for ADA compliance. Therefore, the NJ Arts Access Task Force feels it is imperative that an organization does a thorough assessment of every venue that they plan on having an ongoing relationship with. It is recommended that you contact the organizations you perform in to confirm if they have done a self-assessment and have an <u>up-to-date</u> ADA plan. Ask for a copy of their plan. Many of the major venues in New Jersey are compliant and can provide you with necessary back-up information.</p> <p><u>Include information about each venue’s accessibility and how you have determined and verified the venues’ accessibility in your ADA plan.</u></p>

FACILITY BARRIER REMOVAL/ PHYSICAL ACCESSIBILITY

(Fill this section out for **each** facility that you identified above or secure a comparable assessment from the venue's landlord for your files)

FACILITY SURVEY DATE: _____ Surveyors: _____

Age of Building: _____

Has it been renovated recently? yes no If yes, when? _____

Describe renovation:

Did this improve access? yes no How?

Is the site you are surveying on or eligible for the local, state or national historic registers? yes no

PRIORITY 1: Accessible Approach and Entrance (ADAAG 4.1.2.)

GUIDANCE

People with disabilities should be able to arrive on the site, approach the building, and enter as freely as everyone else. At least one route of travel and entrance should be safe and accessible for people with disabilities.

PARKING AND DROP OFF AREAS

(ADAAG 4.6)
(See Appendix Page x for ADAAG figures 9 & 10)

If you do not have a compliant **parking or drop off area**, be sure to outline in your ADA plan how you accommodate persons with disabilities.

1. Do you have an adequate number of accessible parking spaces?

Total Number of Parking Spaces on your property:

Yes
 No

An acceptable parking space must be at least 8 feet wide with a 5-foot access aisle, in the ratio of the table listed below:

Quantity

Total Number of ADA compliant spaces marked with the International Symbol of Accessibility and NJDOT fine schedule at 60" height?

- a) 1 to 25 parking spaces should have 1 accessible space
- b) 26-50 parking spaces should have 2 accessible spaces
- c) 51-75 parking spaces should have 3 accessible spaces
- d) 76-100 parking spaces should have 4 accessible spaces

For further space requirements of over 100 spaces refer to ADAAG 4.1.2(5a)

Quantity		
2. Do you have an adequate number of van-accessible spaces? <hr/> Quantity	<input type="checkbox"/> Yes <input type="checkbox"/> No	An accessible van space must be 8 feet wide with an 8-foot access aisle. At least one in every 8 accessible spaces shall be a van accessible space with a minimum of one van-accessible space in all cases.
3. Is a vertical clearance of 114 inches minimum clearance provided for a lift-equipped van? (ADAAG 4.6.5)	<input type="checkbox"/> Yes <input type="checkbox"/> No	
4. Is the designated accessible parking space the closest to the accessible entrance door? (ADAAG 4.6.2)	<input type="checkbox"/> Yes <input type="checkbox"/> No	
5. Are each of the accessible parking spaces clearly marked with the International Wheelchair Accessibility Symbol and NJDOT Penalty sign at 60”? (ADAAG 4.6.4)	<input type="checkbox"/> Yes <input type="checkbox"/> No	
6. Is there an enforcement procedure to ensure that accessible parking is used only by those who need it?	<input type="checkbox"/> Yes <input type="checkbox"/> No	It is good practice to implement a policy to check periodically for violators and report them to the proper authorities.
7. Do you have a designated drop off/ passenger-loading zone?	<input type="checkbox"/> Yes <input type="checkbox"/> No	While this is not part of ADA guidelines, this accommodation can be helpful for facilities without accessible parking and accessible route.
8. If you only have on-street parking is there an unobstructed curb cut/curb ramp wide enough for a wheelchair? (ADAAG 4.7)	<input type="checkbox"/> Yes <input type="checkbox"/> No	The curb ramp slope must not exceed 1:12. The flared sides should not exceed 1:10 slope.
ROUTE OF TRAVEL and ACCESSIBLE ENTRANCES (ADAAG 4.3, 4.6, 4.7, 4.13, 4.13.5, 4.13.6, 4.14)		If you do not have a compliant <u>route of travel and accessible entrance</u> be sure to outline in your ADA plan how you accommodate persons with disabilities.
1. Is there an unobstructed pathway from the parking lot or accessible street parking to the accessible entrance of your venue? (ADAAG 4.3, 4.6, 4.7, 4.13.5, 4.13.6)	<input type="checkbox"/> Yes <input type="checkbox"/> No	An exterior accessible route is a continuous, unobstructed path that does not require the use of stairs, is at least 36” wide, consisting of parking access aisles, curb ramps, crosswalks, walks, ramps and lifts.

		<p>In order to be detected by a person with a visual disability using a cane, an object must be within 27 inches off the ground. Objects hanging or mounted overhead must be higher than 80 inches to provide clear head room. It is not necessary to remove objects that protrude 4 inches or less from the wall. (ADAAG 4.4.1)</p> <p>If protruding objects cannot be removed, place a cane detectable object on the ground as a warning barrier.</p>
2. Is someone assigned responsibility for keeping accessible routes free from ice and snow?	<input type="checkbox"/> Yes <input type="checkbox"/> No	Often the accessible route is not maintained in inclement weather, which creates added barriers and hazards to people with disabilities.
3. Do you have a least one entrance that is accessible to persons with disabilities with a level platform (minimum 60" by 60") at the entry and a paved walk or ramp with a slip-resistant surface that is uninterrupted by stairs? (ADAAG 4.14)	<input type="checkbox"/> Yes <input type="checkbox"/> No	Note: Service entrances cannot be considered an accessible entrance unless it is the only entrance to the building (ADAAG 4.14.2)
4. Is your accessible entrance unlocked during hours when building is open to general public?	<input type="checkbox"/> Yes <input type="checkbox"/> No	Eliminate as much as possible the need for assistance- to answer a doorbell, to operate a lift, or to put down a temporary ramp. Ideally, an accessible entrance should be able to be used independently
5. Do signs clearly identify accessible entrances with the international accessibility symbol?	<input type="checkbox"/> Yes <input type="checkbox"/> No	
6. Are signs displayed at all inaccessible entrances directing people to the nearest accessible entrance? (ADAAG 4.1.3[8d])	<input type="checkbox"/> Yes <input type="checkbox"/> No	Install signs near accessible parking and at inaccessible entrances so that persons with disabilities do not have to retrace their approach to your facility to find the accessible entrance.
7. Are the walkways to your entrance wide enough (at least 36") to accommodate a wheel chair? (ADAAG 4.3.3, 4.13.5, 4.13.6) Width: _____	<input type="checkbox"/> Yes <input type="checkbox"/> No	
8. Are all changes of level less than ¼" in height between the accessible parking and accessible entrance?	<input type="checkbox"/> Yes <input type="checkbox"/> No	
9. Are there handrails (1¼" or 1½" diameter) at 34" – 38" high on both sides of the stairs? (ADAAG 4.8.5)	<input type="checkbox"/> Yes <input type="checkbox"/> No	Handrails should have a continuous uninterrupted surface, to allow for constant hand contact from end to end without interruption (Except at doorways and

Diameter of handrail: _____ Height of handrails: _____		openings)
10. Do you have a non-slip ramp in addition to steps that has a running slope of no greater than 1:12? (ADAAG 4.8) Length of Ramp: _____ Rise/Height of Ramp: _____ Surface Type: _____	<input type="checkbox"/> Yes <input type="checkbox"/> No	The maximum length of a 1:12 ramp run shall be 30 feet, with a maximum of a 30 inch rise. Slope is given as a ratio of height to length. 1:12 means for every 1 inch of rise, there needs to be at least 12 inches of ramp length. An 8-inch step in height would require an 8-foot run of ramp. The maximum rise for any run shall be 30" in height. (See Appendix Page x for ADAAG Figures 11, 12, 13) Surfaces of ramps shall be stable, firm, and slip-resistant. Carpet maximum pile thickness shall be 1/2 " and shall be fastened to floor surfaces. Gratings shall have spaces no greater than 1/2".
11. Is there a 5-foot by 5-foot level landing for every 30-foot length of ramp run? Landing length: _____ Landing width: _____	<input type="checkbox"/> Yes <input type="checkbox"/> No	For every thirty-foot section of ramp there needs to be a level platform for resting. If the ramps change directions at landings, the landings must be a minimum of 5' by 5'.
12. Is there a level platform at the top and bottom of the ramp (minimum of 60" long by 42" wide)? (ADAAG 4.8.4) Length: _____ Width: _____	<input type="checkbox"/> Yes <input type="checkbox"/> No	There shall be, at a minimum, landings located at the top and bottom of a ramp or after each ramp run of 30 feet or more, or wherever a ramp changes direction.
13. Are there handrails (1¼" or 1½" diameter) at 34" – 38" high on both sides of the ramp? (ADAAG 4.8.5) Diameter of handrail: _____ Height of handrails: _____	<input type="checkbox"/> Yes <input type="checkbox"/> No	Handrails should have a continuous uninterrupted surface, to allow for constant hand contact from end to end without interruption (Except at doorways and openings)
14. Is the door at least 36 inches wide?	<input type="checkbox"/> Yes <input type="checkbox"/> No	
15. Is the threshold at the door less than ¼" high, or if a beveled edge, no more than ½ inch high? (ADAAG 4.13.8)	<input type="checkbox"/> Yes <input type="checkbox"/> No	If there is a threshold greater than ½ inch high, remove it or modify it with a ramp.
16. Are the doors in the accessible path able to be operated easily with one hand, with a closed fist, or by a person with a limited grasp or strength?	<input type="checkbox"/> Yes <input type="checkbox"/> No	
17. Do interior doors have a maximum opening pressure of 5 pounds? (ADAAG 4.13.11)	<input type="checkbox"/> Yes <input type="checkbox"/> No	Note: There are inexpensive force meters or a fish scale available to measure the force required to open a door.

PRIORITY 2: ACCESS TO PROGRAMS, GOODS AND SERVICES

Ideally, the layout of the building should allow people with disabilities to obtain programs, goods and services without assistance. This section includes all areas that are public spaces.

INTERIOR SPACES

If you do not have a compliant interior space be sure to outline how you accommodate persons with disabilities in your ADA plan.

1. Are there accessible doors leading to all of the following areas?: (ADAAG 4.13)

- Yes
 No

Check off the doors that are accessible:

- Men's Room Width: _____
 Women's Room Width: _____
 Unisex Restroom Width: _____
 Assembly Area Width: _____
 Seating Area Width: _____
 Gallery Width: _____
 Display Areas Width: _____

Note: accessible doors have the following characteristics:
(See Appendix Page xi for ADAAG Fig. 24)

A. clear opening of 32 inches with the door open 90 degrees

B. threshold edge is ¼ inch high or less or no more than ½ inch high if it has beveled edge

C. latch can be opened easily with one hand, with a closed fist, or by a person with a limited grasp or strength

D. doors have a maximum opening pressure of 5 pounds

2. Are the floor surfaces stable, firm and slip-resistant? (ADAAG 4.5)

- Yes
 No

Check type of surface:

- Carpet
 Ceramic tile, Marble, Terrazzo
 Wood
 Other: _____

Ground and floor surfaces along accessible routes and in accessible rooms and spaces including floors, walks, ramps, stairs and curb ramps, shall be stable firm, and slip-resistance. Carpet shall be securely attached; have a firm cushion, pad, or backing, or no cushion or pad and have a maximum pile thickness of ½ inch. Exposed edges of carpet shall be fastened to floor surfaces and have trim along the entire edge.

3. Are wall-mounted objects such as drinking fountains, fire extinguishers, and displays on accessible routes mounted so as not to present a safety hazard? (ADAAG 4.4.1)

- Yes
 No

Objects protruding 4 inches or more from the wall, located more than 27 inches above the floor, and/or are lower than 80 inches above the floor present a hazard for people using guide dogs or canes. (See Appendix Pages xii - xiii for ADAAG Fig. 8)

4. If provided, do signs and room numbers designating permanent rooms and spaces where goods and services are provided comply with the appropriate requirements? (ADAAG 4.30)

- Yes
 No

Permanent signs should be:

mounted with centerline 60 inches from floor

mounted on wall adjacent to latch side of door, or as close as possible?

have raised characters, sized between 5/8 and 2 inches high, with high contrast? (For room numbers, restrooms, stairs, and



		<p>exits)</p> <p><input type="checkbox"/> have Braille text of the same information.</p> <p><input type="checkbox"/> have matte or other non-glare finish on characters and background</p>
<p>5. Are there accessible interior ramps, lifts or elevators provided at <u>all</u> changes in level throughout the public spaces? (ADAAG 4.3)</p> <p>Check off which apply:</p> <p><input type="checkbox"/> Ramp</p> <p><input type="checkbox"/> Elevator</p> <p><input type="checkbox"/> Lift</p>	<p><input type="checkbox"/> Yes</p> <p><input type="checkbox"/> No</p>	<p>If goods and services are inaccessible to patrons with mobility disabilities, outline any reasonable accommodations you offer to provide access. For example, if a second floor exhibit is inaccessible, a videotape or a pictorial replication of the exhibit could be made available on the first level.</p>
<p>6. If there are interior ramps, do they have a running slope of no greater than 1:12 and a stable, slip-resistant surface? (ADAAG 4.8)</p> <p>Length of Ramp: _____</p> <p>Rise/Height of Ramp: _____</p> <p>Surface Type: _____</p>	<p><input type="checkbox"/> Yes</p> <p><input type="checkbox"/> No</p> <p><input type="checkbox"/> Not Applicable</p>	<p>Slope is given as a ratio of height to length. 1:12 means for every 1 inch of rise, there needs to be at least 12 inches of ramp length. An 8-inch step in height would require an 8-foot run of ramp. The maximum rise for any run shall be 30" in height.</p> <p>Surfaces of ramps shall be stable, firm, and slip-resistant. Carpet maximum pile thickness shall be 1/2 " and shall be fastened to floor surfaces. Gratings shall have spaces no greater than 1/2".</p>
<p>7. Are there handrails (1¼" or 1½" diameter) at 34" – 38" high on both sides of the ramp? (ADAAG 4.8.5)</p> <p>Diameter of handrail: _____</p> <p>Height of handrails: _____</p>	<p><input type="checkbox"/> Yes</p> <p><input type="checkbox"/> No</p> <p><input type="checkbox"/> Not Applicable</p>	<p>Handrails should have a continuous uninterrupted surface, to allow for constant hand contact from end to end with out interruption (Except at doorways and openings)</p>
<p>8. If you provide a public elevator or lift, is it unlocked at all times the building is open?</p>	<p><input type="checkbox"/> Yes</p> <p><input type="checkbox"/> No</p> <p><input type="checkbox"/> Not Applicable</p>	
<p>9. Do the interiors of elevator cabs have a minimum floor area of 51" x 68"?</p>	<p><input type="checkbox"/> Yes</p> <p><input type="checkbox"/> No</p> <p><input type="checkbox"/> Not Applicable</p>	<p>In an existing elevator, the min. floor area can be 48" x 48".</p>
<p>10. Is there a sign on both door jams at every floor identifying the floor in raised and Braille Letters. (ADAAG 4.10.5)</p>	<p><input type="checkbox"/> Yes</p> <p><input type="checkbox"/> No</p> <p><input type="checkbox"/> Not Applicable</p>	
<p>11. Do the controls inside the elevator cab have raised and Braille lettering? (ADAAG 4.10.2)</p>	<p><input type="checkbox"/> Yes</p> <p><input type="checkbox"/> No</p> <p><input type="checkbox"/> Not Applicable</p>	

<p>12. Are there both visible and verbal or audible door opening/closing and floor indicators? (ADAAG 4.10.4)</p>	<input type="checkbox"/> Yes <input type="checkbox"/> No <input type="checkbox"/> Not Applicable	<p>1 tone= Up, 2 tones= Down</p>
<p>13. Are all elevator controls between 15 and 48 inches high (up to 54 inches if a side approach)? (ADDAG 4.2, 4.27.3)</p>	<input type="checkbox"/> Yes <input type="checkbox"/> No <input type="checkbox"/> Not Applicable	<p>All controls, dispensers, receptacles, and other operable equipment must be between 15 and 48 inches for a forward reach and between 9 and 54 inches if there is room for a side approach.</p>
<p>14. Does the elevator door close slowly?</p>	<input type="checkbox"/> Yes <input type="checkbox"/> No <input type="checkbox"/> Not Applicable	
<p>15. Is there a communication device in the elevator?</p>	<input type="checkbox"/> Yes <input type="checkbox"/> No <input type="checkbox"/> Not Applicable	
<p>BOX OFFICE/INFORMATION DESK/LOBBY AREA/ RECEPTION AREA/ CONCESSION STAND/ GIFT SHOP</p>		<p>If you do not have a compliant <u>box office, lobby area, reception area, etc.</u>, be sure to outline how you accommodate persons with disabilities in your ADA plan.</p>
<p>1. Do the service counters of your box office, reception desk, information desk, concession stand, gift shop and/or coatroom area have a portion of counter a maximum of 36 inches high and a minimum of 36 inches wide to accommodate a person in a wheelchair? (ADAAG 7.2[2])</p> <p>Area: _____ Width: _____ Height: _____ Area: _____ Width: _____ Height: _____ Area: _____ Width: _____ Height: _____</p>	<input type="checkbox"/> Yes <input type="checkbox"/> No	<p>If your service counters are too high, and there are not immediate plans to remedy the counter, please be sure to identify a reasonable accommodation to serve a patron who is in a wheelchair. For example, a staff member will come around to complete the service transaction and will provide a clipboard for a writing surface.</p>
<p>2. Is the aisle in front of your customer service areas at least 60 inches wide and level to accommodate a turning wheelchair? (ADAAG 4.2.3)</p>	<input type="checkbox"/> Yes <input type="checkbox"/> No	<p>A wheelchair requires a 5' circle or a T-shaped space in order to make a 360-degree turn. (See Appendix Page xiv for ADAAG Fig. 3)</p>
<p>3. Are the floor surfaces stable, firm and slip-resistant? (ADAAG 4.5)</p>	<input type="checkbox"/> Yes <input type="checkbox"/> No	<p>Ground and floor surfaces along accessible routes and in accessible rooms and spaces including floors, walks, ramps, stairs and curb ramps, shall be stable firm, and slip-resistance. Carpet shall be securely attached; have a firm cushion, pad, or backing, or no cushion or pad and have a maximum pile thickness of ½ inch. Exposed edges of carpet shall be fastened to floor surfaces and have trim along the</p>

		entire edge.
<p>4. Is your box office equipped with TTY/text telephone or does your staff know how to use a relay service in order to receive calls from patrons who are deaf or have hearing loss?</p> <p>List TTY #: _____</p>	<input type="checkbox"/> Yes <input type="checkbox"/> No	<p>While ADA Guidelines do not require your box office to have a TTY telephone, it is best practice to have a procedure in place to facilitate communication with your patrons who are deaf or have hearing loss, especially if you are offering services and/or special programming to this community. At minimum, all staff that communicates via phone with patrons should be aware of the relay service (they can be reached by dialing 711).</p>
<p>5. Do you have a procedure for training staff/volunteers in the use of TTY or relay service?</p>	<input type="checkbox"/> Yes <input type="checkbox"/> No	<p>Whether calls are answered by TTY or Relay service, be sure to provide ongoing staff training, especially when there is high staff turnover and/or many part-time staff.</p>
<p>6. Do you have a sign in the lobby or at the box office indicating all available assistive services?</p>	<input type="checkbox"/> Yes <input type="checkbox"/> No	<p>People with hearing loss have difficulty inquiring in noisy lobby areas, and many aren't aware of assistive listening devices unless they are advised of their availability.</p> <p>It is recommended that you use the accessibility symbols along with brief explanations, in large format so that the services are easily identified.</p>
<p>7. If there are tables, are they 34" maximum height, with a minimum of 27" knee space to accommodate a wheelchair?</p>	<input type="checkbox"/> Yes <input type="checkbox"/> No	
<p>ASSEMBLY SPACES (Theatre auditoriums, etc.) (ADAAG 4.33)</p>		<p>If you do not have a compliant <u>assembly space</u> be sure to outline how you accommodate persons with disabilities in your ADA plan.</p>
<p>1. Can patrons using wheelchairs enter the space through the same entry used by the general public?</p>	<input type="checkbox"/> Yes <input type="checkbox"/> No	
<p>2. Do you have the appropriate number of wheelchair seats? (ADAAG 4.1.3[19], Fig. 46)</p> <p>What is the total seating capacity of your: <u>PRIMARY PERFORMANCE SPACE:</u> _____</p> <p>Seats are <input type="checkbox"/> fixed <input type="checkbox"/> movable or <input type="checkbox"/> both</p> <p>If seats are <u>fixed or a combination</u>, list the total number of accessible spaces for persons in wheelchairs _____</p> <p><u>SECONDARY PERFORMANCE SPACE:</u> _____</p>	<input type="checkbox"/> Yes <input type="checkbox"/> No	<p>Use chart below to determine if you have the correct number of wheelchair spaces. Please note that Accessible-seating spaces must be on a <u>level floor area</u> and <u>each space should be a minimum of 36" wide x 48" deep for a rear approach and 60" deep for a side approach. A width of 66" is required for two wheelchair spaces side by side.</u> (ADAAG 4.33.3) (See Appendix page xiv for ADAAG fig.46)</p> <p>Seating Capacity Wheelchair Spaces Accessible Aisle Seats</p>

<p>Seats are <input type="checkbox"/> fixed <input type="checkbox"/> movable or <input type="checkbox"/> both</p> <p>If seats are <u>fixed or a combination</u>, list the total number of accessible spaces for persons in wheelchairs: _____</p>		<p>4-25 1 1</p> <p>26-50 2 1</p> <p>51-100 4 1</p> <p>101-200 4 2</p> <p>201-300 4 3</p> <p>301-400 6 4</p> <p>401-500 6 5</p> <p>501-600* 7 6</p> <p>Over 500, 6 plus 1 for every seating capacity increase of 100</p> <p>It is important to note, <u>an organization cannot request a patron to provide proof of a disability.</u></p>
<p>3. Are 1% of the total seats equipped with removable or no armrest on the end/aisle seats? (ADAAG 4.1.3[19])</p>	<p><input type="checkbox"/> Yes <input type="checkbox"/> No</p>	<p>In addition to the wheelchair locations, 1% of all fixed seats shall be aisle seats with no armrests on the aisle side, or removable or folding armrests on the aisle side. See chart in question 2 above. Aisle seats do not have to be on a level floor.</p> <p>Seats with removable armrests assist people who want to transfer from wheelchairs and others with limited mobility.</p> <p>Removable armrest seats or those without armrests should be marked with a sign or marker. (ADAAG 4.1.3[19])</p> <p>Make sure the chart available at the box office/registration area identifies the wheel chair seating and removable armrest seats.</p>

		When a patron who uses a wheelchair chooses to transfer to a seat, the wheelchair should preferably be stored at their side so they may move about independently and in case of emergency. If such placement creates other hazards, the wheelchair should be accessed conveniently and quickly.
4. Is wheelchair seating integrated into and dispersed throughout the seating areas that are used by the general public? (ADAAG 4.33.3)	<input type="checkbox"/> Yes <input type="checkbox"/> No <input type="checkbox"/> Not Applicable	When the seating capacity exceeds 300, wheelchair spaces shall be provided in more than one location, if possible. Please note, the sight lines for seats provided for patrons with disabilities should be comparable to those of the general public.
5. Does the venue offer a choice of accessible seating areas (when over 300 seats) with choice of admission prices? (ADAAG 4.33.3)	<input type="checkbox"/> Yes <input type="checkbox"/> No	If wheelchair seating is offered at only one price option, the patron purchasing the wheelchair seats must be offered the lowest ticket price available.
6. Is there a companion seat reserved directly adjacent to each wheelchair space? (ADAAG 4.33.3)	<input type="checkbox"/> Yes <input type="checkbox"/> No	Please be aware, that often patrons utilizing the wheelchair seats will have purchased more than two tickets. As with all your patrons, members of a given party, with or without disabilities, should be provided the opportunity to sit together.
7. Is there signage notifying patrons about the availability of wheelchair accessible seating posted at the ticket office? (ADAAG 4.1.3 [19])	<input type="checkbox"/> Yes <input type="checkbox"/> No	Wheelchair Accessible Seating is Available 
8. Can your venue accommodate a person using a wheelchair who is also deaf or hard of hearing and needs to be close to a sign-interpreter?	<input type="checkbox"/> Yes <input type="checkbox"/> No <input type="checkbox"/> Other	
9. Do you have an assistive listening system for all assembly spaces having more than 50 fixed seats? (ADAAG 4.33.6-7) Check what type: <input type="checkbox"/> Infrared <input type="checkbox"/> FM <input type="checkbox"/> Induction Loop	<input type="checkbox"/> Yes <input type="checkbox"/> No	An assistive listening system is required for spaces with over 50 fixed seats or has an audio amplification system. (ADAAG 4.1.3[19], 4.33) An assistive listening system amplifies sound and transmits it to a person's hearing aid or a receiver worn by the patron. In addition, it can be used to transmit audio description for patrons with vision loss. The minimum number of receivers should be equal to 4% of the total number of seats, but no less than two receivers. (ADAAG 4.1.3[19]b)
10. If the listening system provided serves individuals in fixed seats, are such seats located within 50 feet viewing distance of the stage or playing area? (ADAAG 4.33.6)	<input type="checkbox"/> Yes <input type="checkbox"/> No	

<p>11. Is there appropriate signage in the lobby or meeting area indicating the availability of various access services? (ADAAG 4.1.3 [19]b, 4.30)</p>	<input type="checkbox"/> Yes <input type="checkbox"/> No	<p>Hear Every Word!</p>  <p>Assistive Listening Devices are Available at the Counter OR The December 1 performance of <i>The Tempest</i></p>   <p>will be interpreted in American Sign Language and Open Captioned</p> <p>To acquire the access symbols, go to the website for the “Disability Access Symbols Project”: www.gag.org/resources/das.php</p> <p>IF YOU HAVE IT, ADVERTISE IT! Some theatres have even hung signs on the inside of their bathroom stalls advertising the availability of assistive listening systems!</p>
<p>EXHIBITION SPACES (ADA 28 CFR Secs. 35.149.60, 36.303, and 36.304)</p>		<p>Performance organizations that also have an exhibit space as part of their lobby or audience reception space should also fill out this section.</p> <p>The Smithsonian Institute has terrific ADA guidelines for Accessible Exhibition Design. Visit www.si.edu/opa/accessibility/exdesign. Also strongly recommended: <i>Everyone’s Welcome: The Americans with Disabilities Act and Museums</i>, a publication of the American Association of Museums. Visit their website: www.aam-us.org.</p>
<p>1. Are the aisles and pathways between exhibits 36” or more? (ADAAG 4.3.3)</p>	<input type="checkbox"/> Yes <input type="checkbox"/> No	<p>60 inches is preferred to allow room for passing</p>
<p>2. Are the exhibition space floor surfaces stable, firm and slip resistant? (ADAAG 4.5)</p> <p>Check type of surface:</p> <input type="checkbox"/> Carpet <input type="checkbox"/> Ceramic tile, Marble, Terrazzo <input type="checkbox"/> Wood <input type="checkbox"/> Other: _____	<input type="checkbox"/> Yes <input type="checkbox"/> No	<p>Carpeting should be securely attached and any exposed edges fastened to the floor</p> <p>Carpet should be selected with a level or textured loop, or a level cut or uncut pile texture with a maximum pile thickness of ½ inch.</p>
<p>3. Are there areas to sit and rest?</p>	<input type="checkbox"/> Yes <input type="checkbox"/> No	<p>Seating should have back and armrests.</p>

<p>4. Are key objects displayed under a minimum of ten foot-candles of light?</p>	<input type="checkbox"/> Yes <input type="checkbox"/> No	<p>It should be possible to raise light levels for visitors on a requested basis or information on objects is provided in an alternative format that is located near the objects.</p> <p>1 foot-candle is equal to the amount of light produced by one candle that is one foot away from the object. A photographic light meter can be used to determine the foot-candle level of light.</p>
<p>5. Are all freestanding cases displaying exhibit materials at a height between 33-40 inches? (Use measurement to the top of the display case base)</p>	<input type="checkbox"/> Yes <input type="checkbox"/> No <input type="checkbox"/> Other	<p>Please note if objects are to be viewed from above, the top of the transparent case or vitrine (not the base) should be no higher than 36 inches.</p>
<p>6. Are wall-hung items displayed at a comfortable viewing zone for both standing and seated individuals?</p>	<input type="checkbox"/> Yes <input type="checkbox"/> No <input type="checkbox"/> Other	<p><i>See Appendix page xv for diagram</i></p>
<p>7. Do all crowd control barriers (such as stanchions and ropes) have a leading edge or detectable element no higher than 27 inches from the floor so as not to be a hazard and so they are cane detectable?</p>	<input type="checkbox"/> Yes <input type="checkbox"/> No <input type="checkbox"/> Other	
<p>8. Are all the wall-hung, protruding display case exhibits which are over 4 inches in depth/thickness mounted no higher than 33” to 40” above the floor (36 inches is preferred)? (ADAAG 4.4.1-2)</p>	<input type="checkbox"/> Yes <input type="checkbox"/> No <input type="checkbox"/> Other	<p>Items placed between 27 inches and 80 inches above the floor are dangerous for viewers using guide dogs or canes.</p> <p>Consider placing a cane-detectable barrier within 27 inches off the ground if cases do not comply.</p> <p><i>(See Appendix Page xii-xiii)</i></p>
<p>9. Is all signage that identifies permanent rooms and spaces both tactile and visually accessible (restrooms, galleries, gift shop, planetarium, conference rooms, etc)? (ADAAG 4.30)</p>	<input type="checkbox"/> Yes <input type="checkbox"/> No <input type="checkbox"/> Other	<p>Permanent signs must be centered 60 inches above the floor on the latch side of the door.</p> <p>Characters and symbols must be of high-contrast with their backgrounds</p> <p>Signs have a matte or non-glare finish.</p> <p>Letters and numbers must be tactile and accompanied by Grade 2 Braille</p> <p>Tactile letters and numbers are raised 1/32 inch minimum, upper case, sans serif or simple serif, and 5/8 inch to 2 inches in height.</p> <p>Mounting location must allow a person to approach within 3 inches of the sign without encountering protruding objects or entering the swing area of the door.</p>

<p>10. Are exhibit labels of an appropriate size, contrast and position so they are readable by patrons in a wheelchair or people who have vision loss ?</p>	<input type="checkbox"/> Yes <input type="checkbox"/> No <input type="checkbox"/> Other	<p>There are a number of factors that contribute to a person's ability to read exhibit text and labels, including viewing distance, viewing angle, lighting, character size, character style, leading, color, and contrast.</p> <p>Labels and exhibit text should be mounted between 48 inches and 67 inches from the floor. For viewing distances from 3 to 72 inches, an optimum height for mounting labels flat against the wall is 54 inches from the floor to the label's centerline.</p> <p>Case labels should be angled 40 to 45 degrees and placed as close to the front of the case as possible.</p> <p>Rail labels should be mounted so that the top of the label is approximately 40 inches above the floor.</p>
<p>11. Are labels mounted so a person may approach within 3 inches of the label without encountering a barrier or protruding object or setting off an alarm?</p>	<input type="checkbox"/> Yes <input type="checkbox"/> No <input type="checkbox"/> Other	<p>Low vision devices (e.g. a magnifier) often require that individuals be quite close to objects.</p>
<p>12. Is labeling in large, clear type with adequate spacing between characters, in sans serif or simple serif font, high contrast, and on non-glare surface?</p>	<input type="checkbox"/> Yes <input type="checkbox"/> No <input type="checkbox"/> Other	<p>Print should measure a minimum of ¼ inch high (18 point). Size should depend on closest viewing distance. One point equals 1/72 inch. 5/8-inch high letters may be read comfortably by sighted people at a distance of six feet or more.</p> <p>When a font that is difficult to read is used to convey a message (i.e., a time period or theme), duplicate text with sans serif or simple serif fonts may be mounted adjacent to it.</p> <p>Labels silk-screened on Plexiglas should have a screened-on contrasting color background.</p>
<p>13. Are controls (i.e. levers, buttons) for interactive exhibits designed or modified to be accessible to people with disabilities? (ADAAG 4.27)</p>	<input type="checkbox"/> Yes <input type="checkbox"/> No <input type="checkbox"/> Other	<p>Mechanisms to be manipulated on exhibits should be mounted at a maximum height of 54 inches for a side approach and a maximum height of 48 inches if only a frontal approach is available.</p>
<p>14. Are all controls on interactive exhibits 1) operable with only one hand, 2) do not require tight grasping, pinching, or twisting of the wrist, and 3) require no more than five pounds of force to operate?</p>	<input type="checkbox"/> Yes <input type="checkbox"/> No <input type="checkbox"/> Other	<p>Controls should be at least ¾ inch in their smallest dimension</p>

<p>15. Is there a 30-inch x 48-inch clear floor space in front of audio-visual displays or computer interactives with accessible egress to them? (ADAAG 4.2.4)</p>	<input type="checkbox"/> Yes <input type="checkbox"/> No <input type="checkbox"/> Other	<p>The top of the table should be between 28 inches and 34 inches from the floor. Knee space should be at least 27 inches high, 30 inches wide and 19 inches deep. (ADAAG 4.32.3-4)</p>
<p>16. Are manipulatives or devices requiring people to speak directly into them or to put their ears next to objects to listen, no higher than 41 inches from the floor?</p>	<input type="checkbox"/> Yes <input type="checkbox"/> No <input type="checkbox"/> Other	<p>If the keyboard is not a standard (QWERTY) format, it should have raised letters or symbols.</p>
<p>17. Are instructions that are approachable within 3 inches presented in high contrast, sans serif or simple serif fonts, with a minimum capital height of ¼ inch?</p>	<input type="checkbox"/> Yes <input type="checkbox"/> No <input type="checkbox"/> Other	
<h2>ALARMS/SAFETY</h2>		
<p>1. Are alarm systems equipped (when provided) with visual warning lights and mounted 80” above the ground (or 6 inches below the ceiling, whichever is lower)? (ADAAG 4.28)</p>	<input type="checkbox"/> Yes <input type="checkbox"/> No	<p>At a minimum, visual signal appliances shall be provided in buildings and facilities in each of the following areas: Restrooms and any other general usage areas (i.e. lobbies, meeting rooms,) and any other area for common use. See ADAAG 4.28.2 for specifics on visual and audible alarms.</p>
<p>2. Do you have a policy and procedure for safely evacuating persons with disabilities in an emergency?</p>	<input type="checkbox"/> Yes <input type="checkbox"/> No	<p>Organization should work with local Fire Marshall, then send a copy of the plan to your local fire department as well as the local firehouse that would service your building to ensure that they are familiar with your plan and building layout.</p>

PRIORITY 3:

USABILITY OF RESTROOMS (ADAAG 4.1)

When restrooms are open to the public, at least one (either one for each sex or a unisex restroom) should be accessible to people with disabilities.
If you do not have compliant BATHROOM(S) be sure to outline how you accommodate persons with disabilities in your ADA plan.

1. Is there appropriate signage (in both raised lettering and Braille and showing the wheelchair symbol) to indicate accessible restrooms? (ADAAG 4.30.4)	<input type="checkbox"/> Yes <input type="checkbox"/> No	Signage should be placed to the latch side of the door, 60 inches to centerline (NOT on the door itself), complying with the requirements for permanent signage. (ADAAG 4.30.6)
2. Are the restrooms on an accessible route of travel?	<input type="checkbox"/> Yes <input type="checkbox"/> No	

ANSWER QUESTIONS BELOW FOR MEN’S, WOMEN’S, AND UNISEX RESTROOMS. <i>(See Appendix Pages xvii - xix for ADAAG fig. 28, 29, 30, 31,32)</i>	Men’s Restroom	Women’s Restroom	Unisex Restroom	Guidance
1. Is there a designated wheelchair accessible stall that has an area of at least 5 feet by 5 feet, clear of the door swing, OR is there a stall that is less accessible but that provides greater access than a typical stall (either 36 by 69 inches or 48 by 69 inches)? (ADAAG 4.17.3 [fig.30])	<input type="checkbox"/> Yes <input type="checkbox"/> No <input type="checkbox"/> Not Applicable Actual Length _____ Width _____	<input type="checkbox"/> Yes <input type="checkbox"/> No <input type="checkbox"/> Not Applicable Actual Length _____ Width _____	<input type="checkbox"/> Yes <input type="checkbox"/> No <input type="checkbox"/> Not Applicable Actual Length _____ Width _____	
2. In the accessible stall, are there grab bars behind and on the side wall nearest to the toilet at a height of 33-36 inches? (ADAAG 4.17.3[fig.30])	<input type="checkbox"/> Yes <input type="checkbox"/> No <input type="checkbox"/> Not Applicable Actual Height _____	<input type="checkbox"/> Yes <input type="checkbox"/> No <input type="checkbox"/> Not Applicable Actual Height _____	<input type="checkbox"/> Yes <input type="checkbox"/> No <input type="checkbox"/> Not Applicable Actual Height _____	
3. Are the length of the grab bars 42 inches for the side and a minimum of 36 inches for the rear? (ADAAG 4.17.3 [fig.30a])	<input type="checkbox"/> Yes <input type="checkbox"/> No <input type="checkbox"/> Not Applicable	<input type="checkbox"/> Yes <input type="checkbox"/> No <input type="checkbox"/> Not Applicable	<input type="checkbox"/> Yes <input type="checkbox"/> No <input type="checkbox"/> Not Applicable	
4. Is the toilet seat 17 to 19 inches high? (ADAAG 4.17.3 [fig.30])	<input type="checkbox"/> Yes <input type="checkbox"/> No <input type="checkbox"/> Not Applicable	<input type="checkbox"/> Yes <input type="checkbox"/> No <input type="checkbox"/> Not Applicable	<input type="checkbox"/> Yes <input type="checkbox"/> No <input type="checkbox"/> Not Applicable	A readily achievable solution is to add a raised seat.
5. Are there lever, push, or self-closing faucet handles on at least one lavatory (sink basin) so it can be operated with one hand with a closed fist? (ADAAG 4.19.5. 4.27.4)	<input type="checkbox"/> Yes <input type="checkbox"/> No <input type="checkbox"/> Not Applicable	<input type="checkbox"/> Yes <input type="checkbox"/> No <input type="checkbox"/> Not Applicable	<input type="checkbox"/> Yes <input type="checkbox"/> No <input type="checkbox"/> Not Applicable	

6. Is there a minimum of 29” knee space from the floor to the bottom of the lavatory/vanity apron (excluding pipes) and a maximum of 19 inches of depth? (ADAAG 4.19)	<input type="checkbox"/> Yes <input type="checkbox"/> No <input type="checkbox"/> Not Applicable	<input type="checkbox"/> Yes <input type="checkbox"/> No <input type="checkbox"/> Not Applicable	<input type="checkbox"/> Yes <input type="checkbox"/> No <input type="checkbox"/> Not Applicable	Cabinetry may need to be removed or altered to provide space underneath. Make sure hot pipes are covered.
7. Does the men’s restroom or unisex restroom contain at least one urinal with an elongated rim at a maximum height of 17 inches from the floor? (ADAAG 4.18.2)	<input type="checkbox"/> Yes <input type="checkbox"/> No <input type="checkbox"/> Not Applicable	<input type="checkbox"/> Not Applicable	<input type="checkbox"/> Yes <input type="checkbox"/> No <input type="checkbox"/> Not Applicable	
8. Are the soap and other dispensers, towels and hand dryers within reach for a person in a wheelchair and usable with one hand with a closed fist?	<input type="checkbox"/> Yes <input type="checkbox"/> No <input type="checkbox"/> Not Applicable	<input type="checkbox"/> Yes <input type="checkbox"/> No <input type="checkbox"/> Not Applicable	<input type="checkbox"/> Yes <input type="checkbox"/> No <input type="checkbox"/> Not Applicable	Mounted no higher than 54” for front approach and 48” for side approach.
9. Are exposed pipes below the sink covered with insulation or otherwise configured to protect against contact? (ADAAG 4.24.6)	<input type="checkbox"/> Yes <input type="checkbox"/> No <input type="checkbox"/> Not Applicable	<input type="checkbox"/> Yes <input type="checkbox"/> No <input type="checkbox"/> Not Applicable	<input type="checkbox"/> Yes <input type="checkbox"/> No <input type="checkbox"/> Not Applicable	Recess pipes and drains or add insulation on pipes if pipes are exposed.
10. Is the mirror mounted with the bottom edge of the reflecting surface a maximum of 40 inches high? (ADA 4.19.6)	<input type="checkbox"/> Yes <input type="checkbox"/> No <input type="checkbox"/> Not Applicable	<input type="checkbox"/> Yes <input type="checkbox"/> No <input type="checkbox"/> Not Applicable	<input type="checkbox"/> Yes <input type="checkbox"/> No <input type="checkbox"/> Not Applicable	
11. Is the toilet in the accessible water closet 18” (from centerline) from the wall? (ADAAG 4.17.3)	<input type="checkbox"/> Yes <input type="checkbox"/> No <input type="checkbox"/> Not Applicable	<input type="checkbox"/> Yes <input type="checkbox"/> No <input type="checkbox"/> Not Applicable	<input type="checkbox"/> Yes <input type="checkbox"/> No <input type="checkbox"/> Not Applicable	Other national codes allow a distance from 16 – 18 inches to centerline

This section includes all items that are not covered above.

PRIORITY 4:

ADDITIONAL ACCESS

1. Do you have an accessible public telephone available in the registration/information/ lobby area? (ADAAG 4.31)	<input type="checkbox"/> Yes <input type="checkbox"/> No	An accessible public phone has the following features: a. Coin slot at a height of no more than 54” above the finished floor, b. Clear level space of 30” deep x48” wide in front of phone, c. A volume control with identifying signage, d. An electrical outlet and level shelf within 18” of at least one phone for a portable TTY e. Push button controls
Height of coin slot: _____ inches Space in front of phone: ___ deep X ___ wide		
2. Is the public telephone equipped with a TTY or is a TTY located in the information area/box office available for public use? (ADAAG 4.31.9, 4.1.3[17])	<input type="checkbox"/> Yes <input type="checkbox"/> No	If there are four or more public phones in the building, one of the phones should be equipped with a text telephone. If the public telephone is not equipped with a Text telephone or designed to accommodate a portable text phone, an equivalent facilitation may be provided, such as utilizing TTY in the box office or at information desk.

3. Are there signs at all regular phones indicating the location(s) of the public TTY phone(s)?	<input type="checkbox"/> Yes <input type="checkbox"/> No	Signage should make it easy for patrons to locate a public TTY phone.
4. Do you have an accessible bi-level public drinking fountain? (ADAAG 4.15) An accessible fountain has (check off applicable items below): <input type="checkbox"/> a spout no higher than 36" from the floor, <input type="checkbox"/> a control on the front face of the fountain, & <input type="checkbox"/> a minimum of 30" deep x 48" wide level, clear floor space in front of the fountain	<input type="checkbox"/> Yes <input type="checkbox"/> No	If drinking fountain is not compliant, outline how you accommodate persons with disabilities (i.e. a cup dispenser attached to the fountain, Bottled water dispenser provided).
TECHNICAL FACILITIES: STAGES & DRESSING ROOMS:		These questions are significant for artists with disabilities or persons with disabilities who wish to participate in the arts or lecture presentations, as well as for prospective audience members who attend backstage events.
1. Is the backstage, pit and stage area accessible to people in wheelchairs?	<input type="checkbox"/> Yes <input type="checkbox"/> No	
2. Do patrons using wheelchairs have access to your special events, e.g. opening nights, backstage tours and parties?	<input type="checkbox"/> Yes <input type="checkbox"/> No	
3. Does your facility provide accessible dressing rooms, green rooms, etc for performers? <i>An accessible dressing room should have at least the following features. Check off those that apply:</i> <input type="checkbox"/> <i>entry of 36 inches,</i> <input type="checkbox"/> <i>clear floor space of a diameter of 60 inches</i> <input type="checkbox"/> <i>open knee space under the dressing table</i> <input type="checkbox"/> <i>adjustable makeup mirrors</i> <input type="checkbox"/> <i>light switches no more than 48" above finished floor</i>	<input type="checkbox"/> Yes <input type="checkbox"/> No	Counters should be a maximum of 36" high, and no less than 27" high.
4. Is there an unobstructed route from the stage or performing area to the dressing room?	<input type="checkbox"/> Yes <input type="checkbox"/> No	

NEW JERSEY STATE AND COUNTY CENSUS DATA - 2000*

County	Population	Disabled*	% Of Population
Atlantic	252,552	46,698	18.5%
Bergen	884,118	129,516	14.6%
Burlington	423,394	60,198	14.2%
Camden	508,932	88,143	17.3%
Cape May	102,326	19,396	19.0%
Cumberland	146,438	29,397	20.1%
Essex	793,633	158,244	19.9%
Gloucester	254,673	39,385	15.5%
Hudson	608,975	134,428	22.1%
Hunterdon	121,989	11,945	9.8%
Mercer	350,761	55,055	15.7%
Middlesex	750,162	112,382	14.9%
Monmouth	615,301	84,529	13.7%
Morris	470,212	58,875	12.5%
Ocean	510,916	95,010	18.6%
Passaic	489,049	97,455	19.9%
Salem	64,285	12,032	18.7%
Somerset	297,490	34,432	11.6%
Sussex	144,166	17,976	12.5%
Union	522,541	87,207	16.7%
Warren	102,437	15,508	15.1%
Total	8,414,350	1,389,811	16.5%

*age 5 and older

Source: <http://quickfacts.census.gov/qfd>. % of Population estimates by Don Ehman. Rounded off to nearest .1%

**SAMPLE JOB DESCRIPTION
FOR AMERICANS WITH DISABILITIES ACT
(ADA) COORDINATOR**

Definition: Under the direction of supervisory administrator, the ADA coordinator is responsible for coordinating activities necessary to ensure compliance with the Americans with Disabilities Act of 1990 (ADA) and the Federal Rehabilitation Act of 1973; may supervise support staff, does other related duties as required.

NOTE: The following examples of work are for illustrative purposes only. A particular position using this title may not perform all duties listed in this job specification. Conversely, all duties performed on the job may not be listed.

1. Administer 504/ADA programs
2. Collect and maintain a library of ADA regulations and supplementary materials.
3. Develop and supervise the ADA advisory board.
4. Works with staff and administrative leaders to write long-range ADA plan and ensure implementation of the plan's goals.
5. Obtains price quotes for special purchases of equipment, materials, or supplies for implementing reasonable accommodation or public access.
6. Develops ADA program budget.
7. Develop and maintain good working relations with people and artists with disabilities as well as organizations representing people with disabilities.
8. Provide sensitivity training to staff and board on annual basis.
9. Provides technical information and advice to staff, peers, and management.
10. Recommends resolutions to grievances. Maintain correspondence and documentation of the compliance procedure.
11. Oversees plans for special events so that accessibility to events is barrier free.
12. Arranges special requests for accommodations, alternate formats, etc. with appropriate staff members.

JOB REQUIREMENTS:

1. Knowledge of provisions of Titles I, II and III of ADA.
2. Knowledge of practices and activities covered by employment nondiscrimination requirements of ADA.
3. Knowledge of evaluating public access to facilities and programs and services
4. Knowledge of training principles and techniques
5. Deep understanding of all aspects of the organization
6. Strong communication skills to unify ADA efforts among administrative staff and to reach out to patrons with disabilities

Communicating with People with Disabilities

Employees or customers who have disabilities will feel most comfortable at your place of business if you consider these suggestions for effective communication

General Considerations

■ Do not be afraid to make a mistake when meeting and communicating with someone with a disability. Try following the suggestions below. Imagine how *you* would react if you were in similar situations. Keep in mind that a person who has a disability is a person, and, like you, is entitled to the dignity, consideration, respect, and rights you expect for yourself.

■ Treat adults as adults. Address people with disabilities by their first names only when extending the same familiarity to all others present. (Never patronize people by patting them on the head or shoulder.)

■ Relax. If you don't know what to do, allow the person who has a disability to put you at ease.

■ If you offer assistance and the person declines, do not insist. If it is accepted, ask how you can best help, and follow directions. Do not take over.

■ If someone with a disability is accompanied by another individual, address the person with a disability directly rather than speaking through the other person.

“People First” Terminology

■ Place the person before the disability. Say “person with a disability” – rather than “disabled person.”

■ Avoid referring to people by the disability they have, i.e., “an epileptic,” “blind people.” A person is not a condition. Rather, refer to “a

person with epilepsy,” or “people who are blind.”

■ People are not “bound” or “confined” to wheelchairs. They use them to increase their mobility and enhance their freedom. It is more accurate to say “wheelchair User” or “person who uses a wheelchair.”

Physical Disabilities

■ Do not make assumptions about what a person can and cannot do. A person with a physical disability is the best judge of his or her own capabilities.

■ Do not push a person's wheelchair or grab the arm of someone walking with difficulty, without first asking if you can be of assistance. Personal space includes a person's wheelchair, crutches, or other mobility aid.

■ Never move someone's crutches, walker, cane, or other mobility aid without permission. When speaking to a person using a wheelchair for more than a few minutes, try to find a seat for yourself so the two of you are at eye level.

Visual Disabilities

Identify yourself when you approach a person who is blind. If a new person approaches, introduce him or her.

■ It is appropriate to touch the person's arm lightly when you speak so that he or she knows you are speaking to him or her.

■ Face the person and speak directly to him or her. Use a normal tone of voice.

FACT SHEET 3

Communicating with People with Disabilities Cognitive Disabilities

- Don't leave without saying you are leaving.
- If you are offering directions, be as specific as possible, and point out obstacles in the path of travel. Use clock cues ("The door is at 2 o'clock").
- Alert people who are blind or visually impaired to posted information. Never pet or otherwise distract a guide dog unless the owner has given you permission.
- You may offer assistance if it seems needed, but if your offer is declined, do not insist. If your offer is accepted, ask the person how you can best help.

Hearing Disabilities

- Ask the person how he or she prefers to communicate.
- If you are speaking through an interpreter, remember that the interpreter may lag a few words behind especially if there are names or technical terms to be finger spelled so pause occasionally to allow him or her time to translate completely and accurately.
- Talk directly to the person who is deaf or hard of hearing, not to the interpreter. However, although it may seem awkward to you, the person who is deaf or hard of hearing will look at the interpreter and may not make eye contact with you during the conversation.
- Before you start to speak, make sure you have the attention of the person you are addressing. A wave, a light touch on the shoulder, or other visual or tactile signals are appropriate ways of getting the person's attention.
- Speak in a clear, expressive manner. Do not over-enunciate or exaggerate words.

■ Unless you are specifically requested to do so, do not raise your voice. Speak in a normal tone; do not shout.

■ To facilitate speech reading, face into the light, and keep your hands and other objects away from your mouth.

■ If the person is speech reading, face the person directly and maintain eye contact. Don't turn your back or walk around while talking. If you look away, the person might assume the conversation is over.

■ While you are writing a message for someone who is deaf or hard of hearing, don't talk, since the person cannot read your note and your lips at the same time.

■ If you do not understand something that is said, ask the person to repeat it or to write it down. The goal is communication; do not pretend to understand if you do not.

■ If you know any sign language, try using it. It may help you communicate, and it will at least demonstrate your interest in communicating and your willingness to try.

Speech Disabilities

- Talk to people with speech disabilities as you would talk to anyone else.
- Be friendly; start up a conversation.
- Be patient; it may take the person a while to answer.
- Give the person your undivided attention.
- Ask the person for help in communicating with him or her. If the person uses a communication device such as a manual or electronic communication board, ask the person how best to use it.

Produced by **Adaptive Environments Center** under contract to Barrier Free Environments, NIDRR grant #H133D10122

FACT SHEET 3

Communicating with People with Disabilities Cognitive Disabilities

- Speak in your regular tone of voice.
- Tell the person if you do not understand what he or she is trying to say. Ask the person to repeat the message, spell it, tell you in a different way, or write it down.
- To obtain information quickly, ask short questions that require brief answers or a head nod. However, try not to insult the person's intelligence with over-simplification.

Cognitive Disabilities

- Treat adults with cognitive disabilities as adults.
- When speaking to someone who has a cognitive disability, try to be alert to his or her responses so that you can adjust your method of communication if necessary. For example, some people may benefit from simple, direct sentences or from supplementary visual forms of communication, such as gestures, diagrams, or demonstrations.
- Use language that is concrete rather than abstract. Be specific, without being too simplistic. Using humor is fine, but do not interpret a lack of response as rudeness. Some people may not grasp the meaning of sarcasm or other subtleties of language.
- People with brain injuries may have short-term memory deficits and may repeat themselves or require information to be repeated.
- People with auditory perceptual problems may need to have directions repeated, and may take notes to help them remember directions or the sequence of tasks. They may benefit from watching a task demonstrated.

- People with perceptual or "sensory overload" problems may become disoriented or confused if there is too much to absorb at once. Provide information gradually and clearly. Reduce background noise if possible.

- Repeat information using different wording or a different communication approach if necessary. Allow time for the information to be fully understood.

- Don't pretend to understand if you do not. Ask the person to repeat what was said.

- In conversation, people with mental retardation may respond slowly, so give them time. Be patient, flexible, and supportive.

- Some people who have a cognitive disability may be easily distracted. Try not to interpret distraction as rudeness.

- Do not expect all people to be able to read well. Some people may not read at all.

Please note: This material is based in part on *Achieving Physical and Communication Accessibility*, a publication of the National Center for Access Unlimited, and *Community Access Facts*, an Adaptive Environments Center publication.

Produced by **Adaptive Environments Center** under contract to Barrier Free Environments, NIDRR grant #H133D10122

SAMPLE Grievance Procedure #1

This procedure is defined for use in the event that ORGANIZATION receives a complaint from the public in response to its action or inaction as it endeavors to comply with the Americans with Disabilities Act of 1990. All concerns voiced by the public will be considered as serious and will be addressed and documented. The purpose and goal of this Grievance Procedure is to:

- resolve problems within the limits of the organization's resources,
- determine a solution that is mutually acceptable to the complainant and the organization,
- recommend later solutions that permit greater access,
- provide a forum for the public discussion of concerns.

Committee

Members of the organization's Accessibility Advisory Committee will form a Grievance Committee. This subcommittee will include the Executive Director and/or ADA coordinator and one committee member representing: an artistic discipline/artist who has a disability and one member from a service organization serving people with disabilities.

Step One

The Executive Director/ADA Coordinator will meet with the complainant on an informal basis to determine the nature of the concern, discuss the issue, and answer any questions the individual may have. This meeting is to be conducted in a positive atmosphere.

The complainant will receive a copy of the organization's ADA Compliance Plan.

If the Executive Director/ADA Coordinator determines that immediate action can be taken permitting access in the manner requested by the complainant, it shall be done under the authority of the Executive Director.

The Executive Director/ADA Coordinator will document the problem and the resolution. That documentation will be reported to the Board of Trustees at the next scheduled meeting. That report will become part of the official proceedings and record of the meeting.

Step Two

If an immediate and satisfactory solution is not found and the individual complainant wishes to lodge a formal complaint, the Executive Director/ADA Coordinator will assist the complainant to prepare a written description of the problem. The complainant will be advised that the written complaint will be submitted to the Grievance Committee and the committee members' names will be given to the complainant at that time. The written description must include:

- Contact information: complainant's name, address, phone number(s), e-mail
- Description: nature of the complaint in detail
- Location/Time: when and where the person was denied access
- Request: what the complainant believes could or should be done and how this recommendation would resolve the issue.

The Executive Director/ADA Coordinator will notify the Advisory Committee of the complaint and forward a copy of the written complaint to the Grievance Committee members.

Step Three

The Executive Director/ADA Coordinator will call a meeting of the Grievance Committee, which the complainant will attend. The meeting will take place in a barrier-free location, within one (1) month of the filing of the complaint (schedules permitting) but no more than sixty (60) days after complaint is filed.

The meeting's agenda shall include:

- Presentation by the complainant
- Discussion
- Recommendations for resolution
- Timeline for implementation
- Follow-through assigned to one committee member
- Committee vote on the recommendation

Committee considerations in preparing their recommendations and findings:

- Merit of complaint: is the complaint valid, was access denied?
- Circumstances: why was access not possible, what created that condition?
- Condition: is this a condition that is standard or unusual to the situation (e.g. interpreter cancelled last minute)?
- Policy: did the lack of access result from an existing policy, is a new policy warranted?
- Solution: what must happen to allow access, what alternatives exist?
- Mitigating Factors: are there conditions, resources, and limitations that must be considered?

Do these conditions prevent a resolution; how, why?

- Recommendations: which solution is to be employed, who will carry out the solution, is funding required, where is funding coming from, what is the timeline for implementation?
- Follow-up: is any further contact with the complainant required? If so, how?

The complainant is advised that the recommendations will be presented to the Board of ORGANIZATION, which will vote on the recommendations, especially when a policy statement or funding allocation is sought. The complainant will be required to sign the recommendation to be submitted to the Board as acceptable to them and agreeing that if the recommendation(s) is followed, the matter is closed.

Step Four

The Grievance Committee's findings and recommendations will be forwarded to the same committee members who received the original complaint and to the complainant.

At the next scheduled meeting of the ORGANIZATION Board, the recommendation(s) will be presented for vote and acceptance of the findings.

In the event the Board does not accept the recommendation or findings, the complainant will be notified and the Grievance Committee reconvened.

OR
The recommended solution is implemented and incorporated into ORGANIZATION'S future ADA compliance policy and activity.

SAMPLE ADA Grievance Procedure #2

ORGANIZATION has developed a long-range plan to not only comply with the law of the Americans with Disabilities Act, but with the spirit of the regulations. A grievance procedure provides for prompt and fair resolution of complaints received from the public. It is our goal that our long-range plan efforts will preclude the need for such resolution procedures. However, it is the function of the grievance procedure to resolve problems to the best of our ability by determining a solution that provides improved access. All complaints will receive immediate attention. A grievance committee has been established which consists of *ORGANIZATION'S* ADA coordinator, two Access Advisory Board Members, the *ORGANIZATION'S* Managing Director, and when complaints pertain to the physical facility, the *ORGANIZATION'S* landlord.

The procedure is as follows:

1. *ORGANIZATION'S* ADA coordinator will meet with the complainant on an informal basis to determine the nature of the concern, to discuss the issue and answer any questions raised by the patron. The complainant may designate another person to act in their stead and other grievance committee members or *ORGANIZATION'S* staff may join this meeting should they have pertinent information to resolve the matter. Once information is gathered, the ADA Coordinator will discuss potential solutions with *ORGANIZATION* management and determine what can be readily achieved. Proposed solutions will be presented to the complainant.
2. If an immediate action is not identified and/or the patron wishes to lodge a formal complaint, it should be made in writing to the ADA Coordinator. The written complaint must include:
 - a. Name, address and telephone number.
 - b. A description of the alleged violation and time.
 - c. What action the patron recommends to resolve the issue.
3. An informal investigation, as required, shall be performed by the ADA Coordinator upon the filing of the complaint. This provides the opportunity for all interested parties to submit documentation and other support information relevant to the complaint.
4. Within 60 days of the filed complaint, a meeting of the grievance committee and the complainant will be scheduled to take place. The patron will present their grievance for discussion with the committee. All parties will have the opportunity to present their positions in an equitable, hospitable environment. Recommendations for accommodation and a reasonable timeline will be agreed upon. The recommendation will be voted upon by *ORGANIZATION'S* Board of Trustees within 90 days of the meeting between the grievance committee and the complainant.

SAMPLE CONTRACT RIDER FOR TOURING COMPANIES

ADA COMPLIANCE RIDER

Organization makes a good-faith effort to comply with all requirements of the Americans with Disabilities Act of 1990 (ADA) and has developed a long-range plan to become ADA compliant. Included are all aspects of *Organization's* programming, employment practices and facilities.

Organization requests that in keeping with this that all Presenters of *Organization* demonstrate a good-faith effort towards compliance with ADA. Please read the listing below and indicate services you are currently able to provide, and return it signed, with your contract.

Organization may be able to provide some of these services to our Presenters. Please contact: Ms./Mr. X, the *Organization* ADA coordinator at 555-123-4567.

FACILITY	YES	NO	PROGRAM ACCOMMODATIONS	YES	NO
Wheelchair Access (House)	<input type="checkbox"/>	<input type="checkbox"/>			
Wheelchair Seating	<input type="checkbox"/>	<input type="checkbox"/>	Audio Description	<input type="checkbox"/>	<input type="checkbox"/>
Wheelchair Access (Stage)	<input type="checkbox"/>	<input type="checkbox"/>	Sensory Seminars	<input type="checkbox"/>	<input type="checkbox"/>
Box Office Staff Trained	<input type="checkbox"/>	<input type="checkbox"/>	Open Captioning	<input type="checkbox"/>	<input type="checkbox"/>
Front of House Trained	<input type="checkbox"/>	<input type="checkbox"/>	Sign Interpretation	<input type="checkbox"/>	<input type="checkbox"/>
TTY	<input type="checkbox"/>	<input type="checkbox"/>	Large Print Programs	<input type="checkbox"/>	<input type="checkbox"/>
Assistive Listening System	<input type="checkbox"/>	<input type="checkbox"/>	Braille Programs	<input type="checkbox"/>	<input type="checkbox"/>

PROMOTION	YES	NO	OTHER	YES	NO
Use Access Symbols	<input type="checkbox"/>	<input type="checkbox"/>	Provide Transportation	<input type="checkbox"/>	<input type="checkbox"/>
Interior Signage	<input type="checkbox"/>	<input type="checkbox"/>	Reduced Ticket Rates	<input type="checkbox"/>	<input type="checkbox"/>
Brochures in alternate format	<input type="checkbox"/>	<input type="checkbox"/>	Companion Reduced Ticket Rates	<input type="checkbox"/>	<input type="checkbox"/>

Please add anything that you offer to People with Disabilities that is not mentioned:

Presenting Organization
Date

Officer

Address/State

Date of Organization's Appearance

Presenter Phone

Presenter FAX

Presenter Email

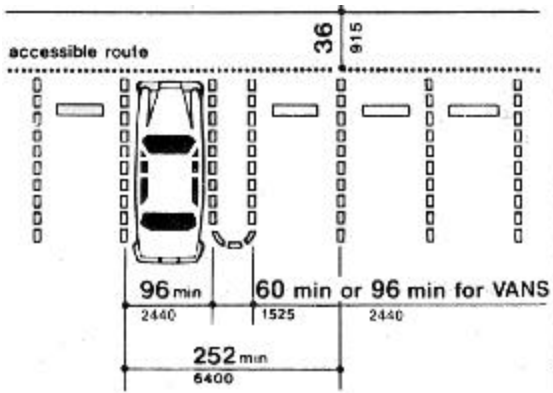

Figure 9: Dimensions of Parking Spaces

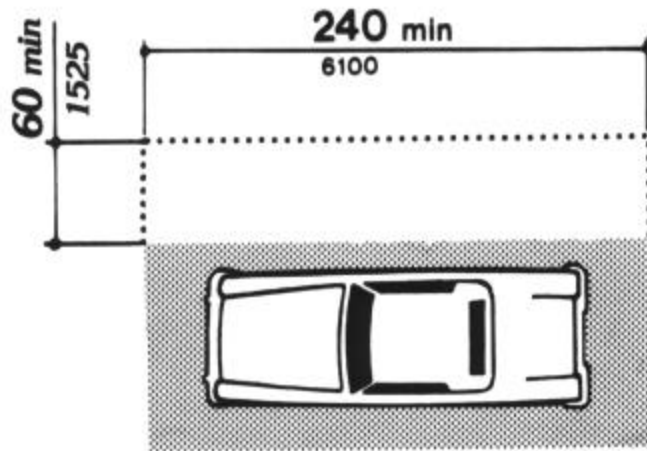

Figure 10: Access Aisle at Passenger Loading Zones

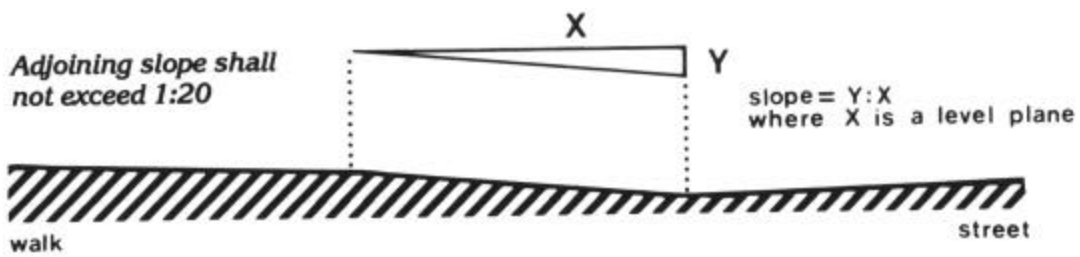
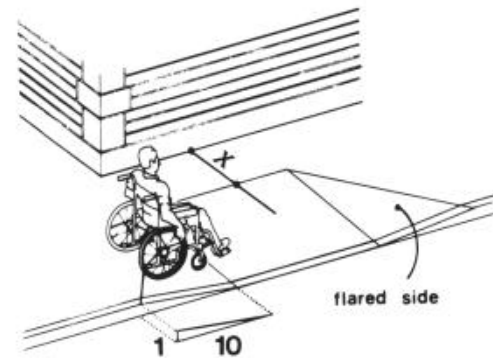
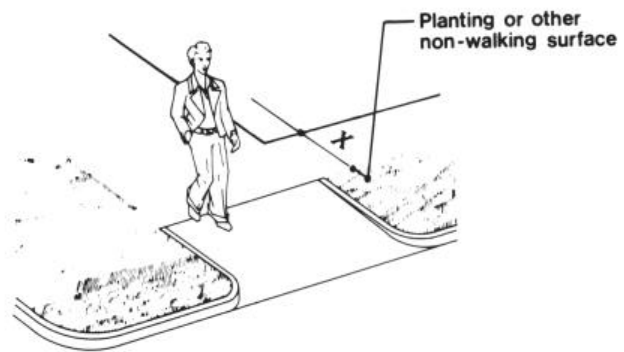

Figure 11: Measurement of Curb Ramp Slopes



(a) Flared Sides



(b) Returned Curb

Figure 12: Sides of Curb Ramps

If X is less than 48 in, then
The slope of the flared side
Shall not exceed 1:12

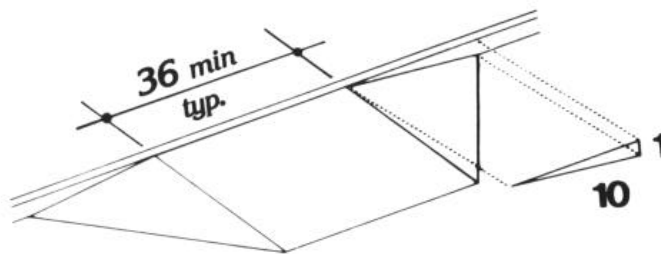

Figure 13: Built-up Curb Ramp

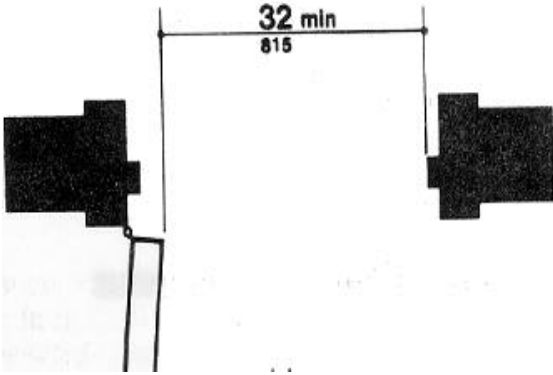

Figure 24a
Clear Doorway Width and Depth
Detail Figure

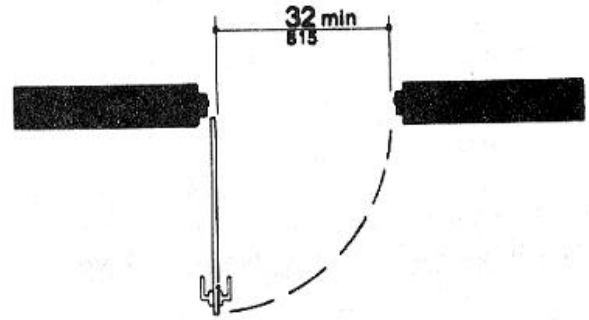

Figure 24b
Clear Doorway Width and Depth
Hinged Door

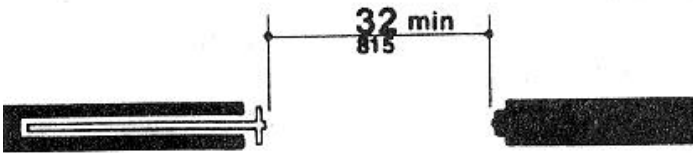

Figure 24c
Sliding Door

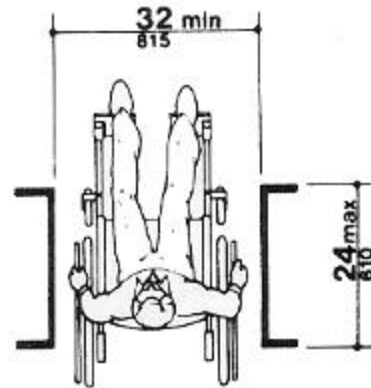

Figure 24e Clear Doorway Width and Depth
Maximum Doorway Depth

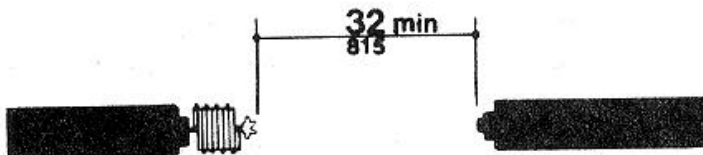

Figure 24d
Folding Door

Figure 24
Clear Doorway Width and Depth

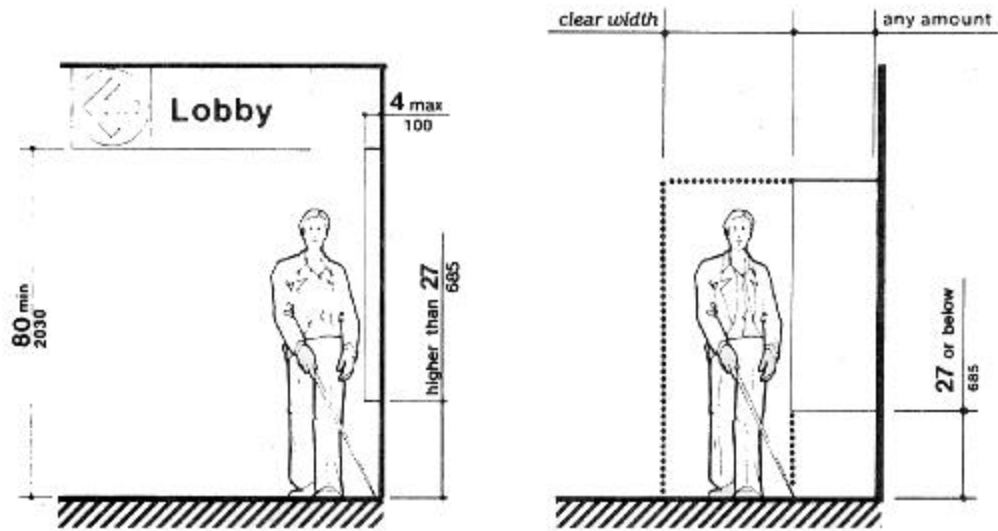

Figure 8a
Protruding Objects
Walking Parallel to a Wall

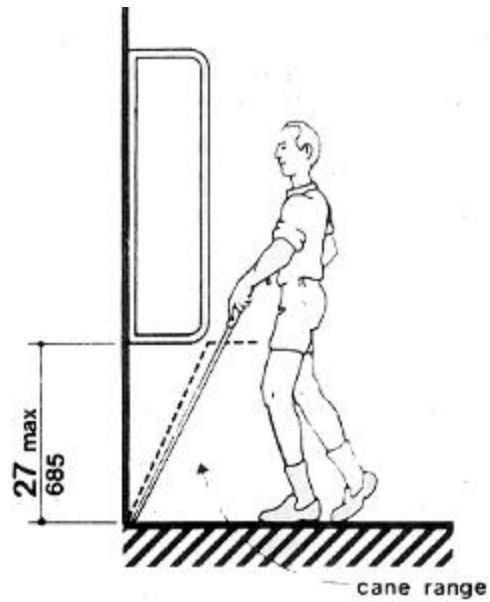

Figure 8b
Protruding Objects
Walking Perpendicular to a Wall

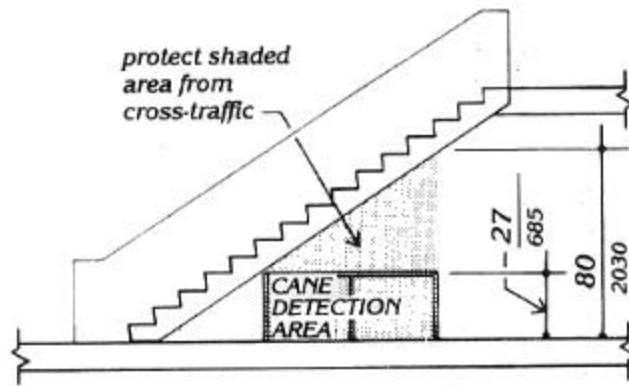

Figure 8c-1
Protruding Objects
Overhead Hazards

Overhead Hazards. As an example, the diagram illustrates a stair whose underside descends across a pathway. Where the headroom is less than 80 inches, protection is offered by a railing (2030 mm) which can be no higher than 27 inches (685 mm) to ensure detectability.

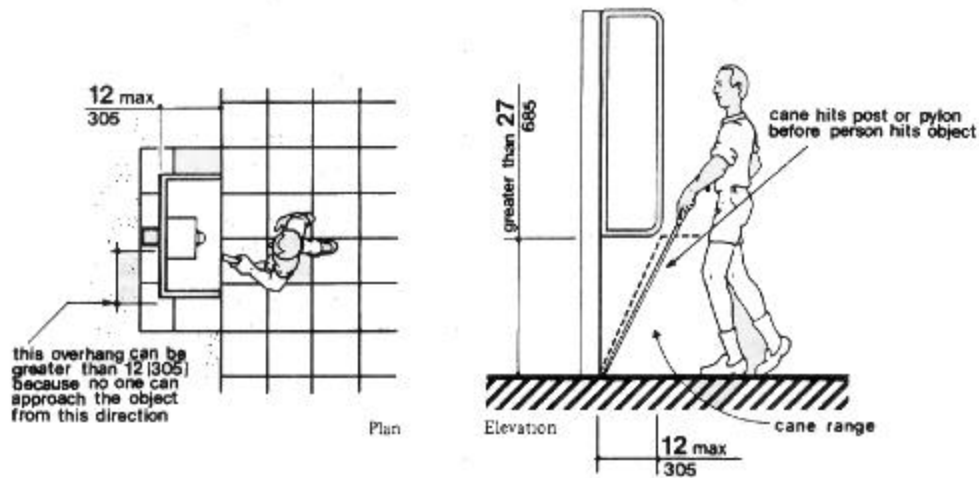

Figure 8d
Protruding Objects
Objects Mounted on Posts or Pylons

The diagram illustrates an area where an overhang can be greater than 12 inches (305 mm) because the object cannot be approached in the direction of the overhang.

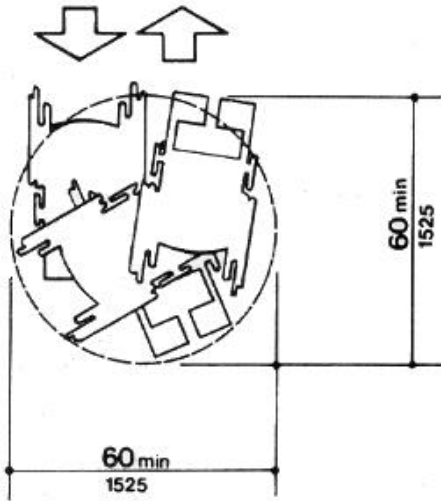

Figure 3a
Wheelchair Turning Space
60-in (1525 mm) Diameter Space

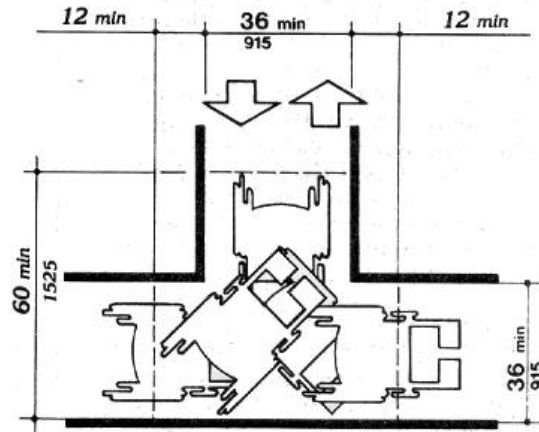

Figure 3b
Wheelchair Turning Space
T-Shaped Space for 180 Degree Turns

The T-shape space is 36 inches (915 mm) wide at the top and stem within a 60 inch by 60 inch (1525 mm by 1525 mm) square.

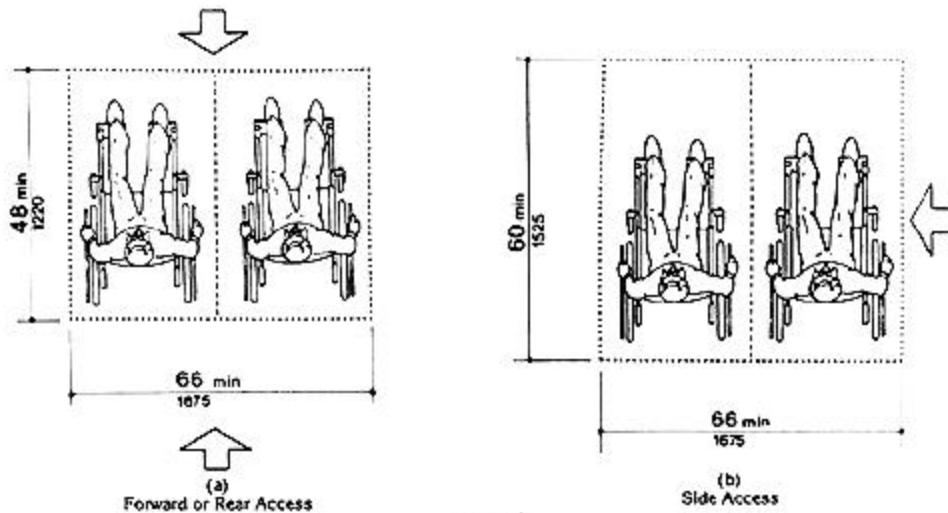

Fig. 46
Space Requirements for Wheelchair
Seating Spaces In Series

Fig. 46(a) Forward or Rear Access. If seating space for two wheelchair users is accessed from the front or rear, the minimum space required is 48 inches (1220 mm) deep by 66 inches (1675 mm) wide.

Fig. 46(b) Side Access. If seating space for two wheelchair users is accessed from the side, the minimum space required is 60 inches (1525 mm) deep by 66 inches (1675 mm) wide.

Comfortable Viewing Zone

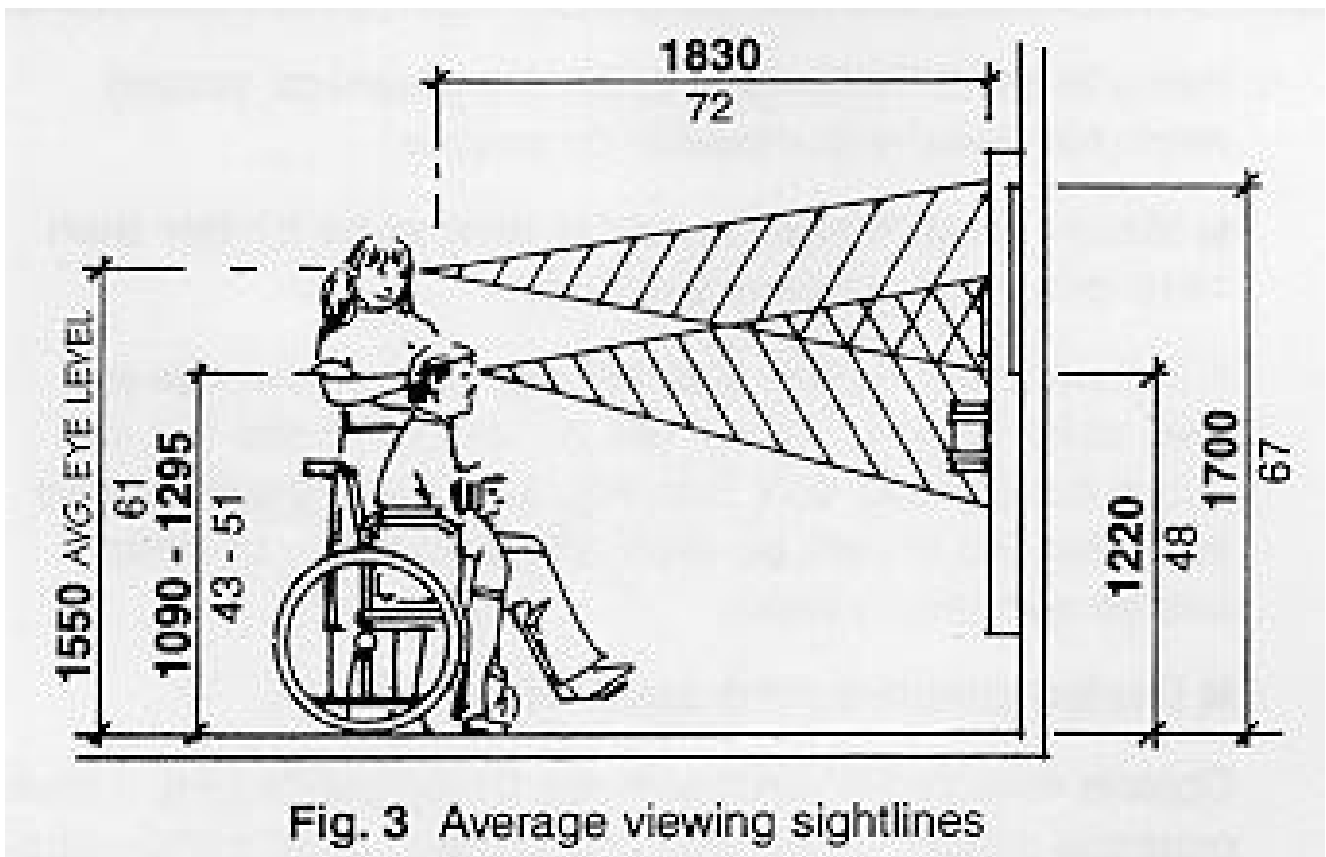

Fig. 3 Average viewing sightlines

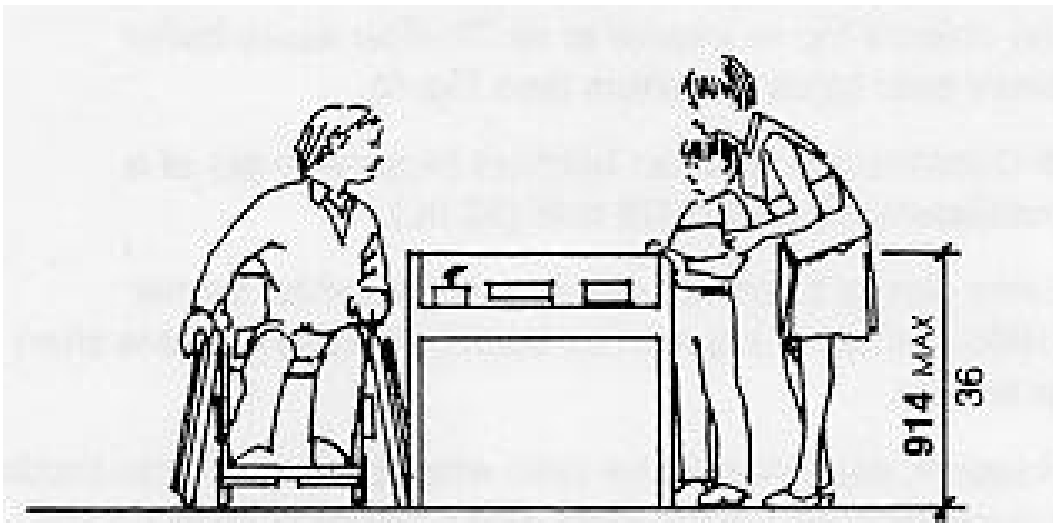
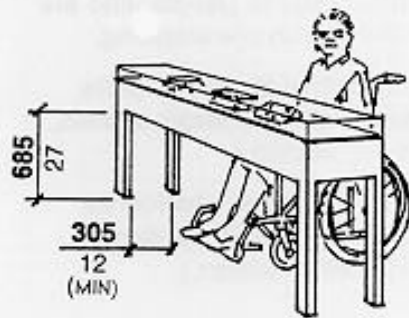

Fig. 6 Height of table case



Maintaining base of table case at 685 mm (27 in.) above floor provides both cane detection and knee space for wheelchairs users.

Fig. 29 Table case height

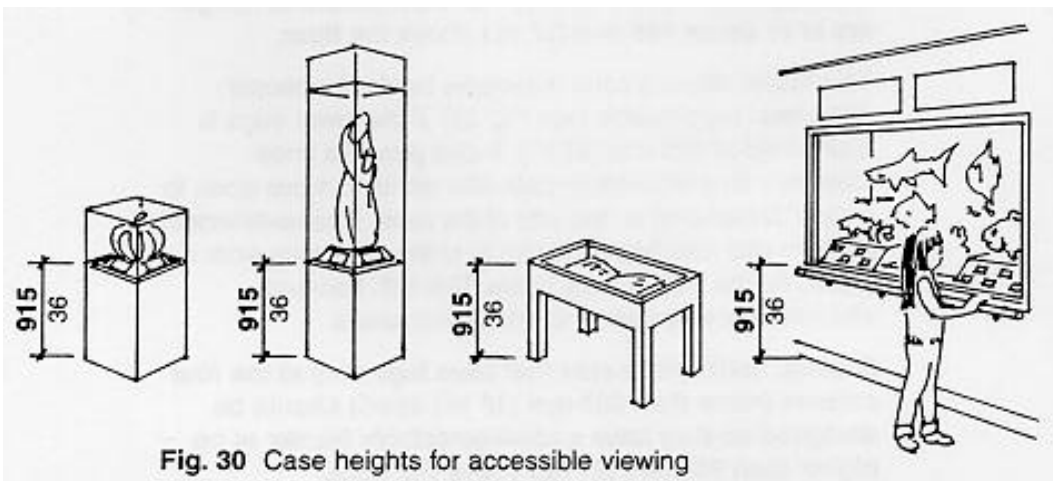

Fig. 30 Case heights for accessible viewing

EXHIBIT AND DISPLAY CASES

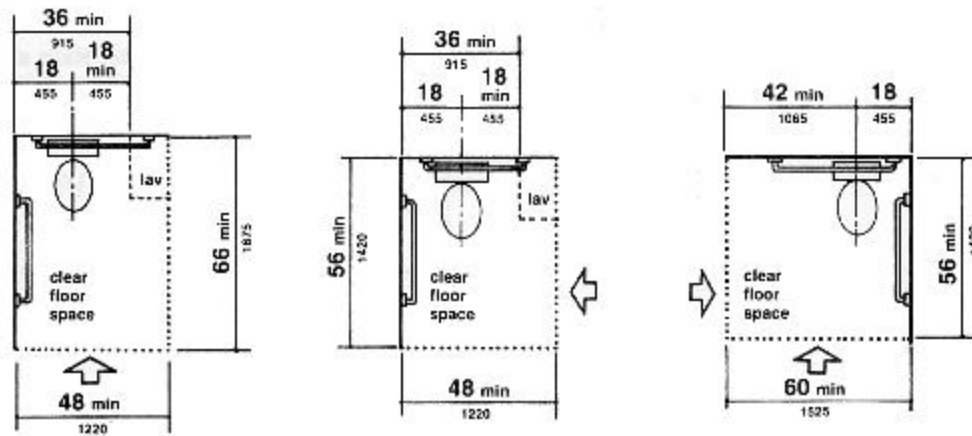

Figure 28
Clear Floor Space at Water Closets

For a front transfer to the water closet, the minimum clear floor space at the water closet is a minimum 48 inches (1220 mm) in width by a minimum of 66 inches (1675 mm) in length. For a diagonal transfer to the water closet, the minimum clear floor space is a minimum of 48 inches (1220 mm) in width by a minimum of 56 inches (1420 mm) in length. For a side transfer to the water closet, the minimum clear floor space is a minimum of 60 inches (1525 mm) in width by a minimum of 56 inches (1420 mm) in length. (4.16.2, A4.22.3)

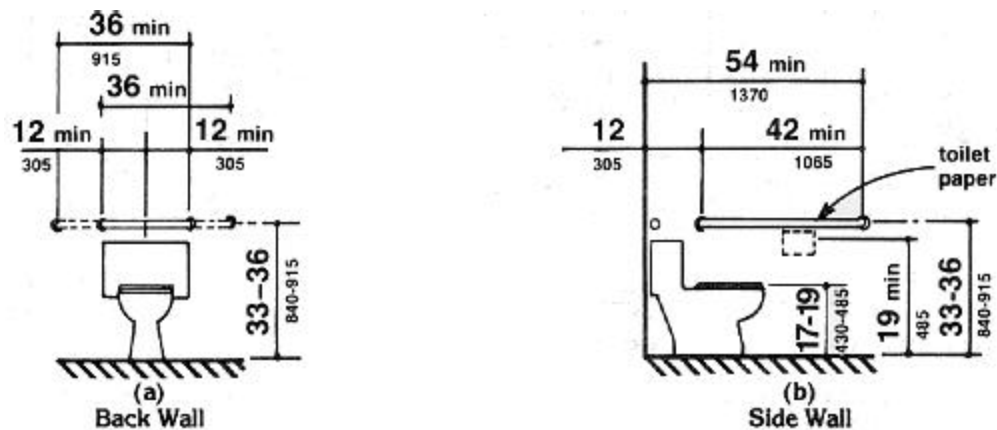
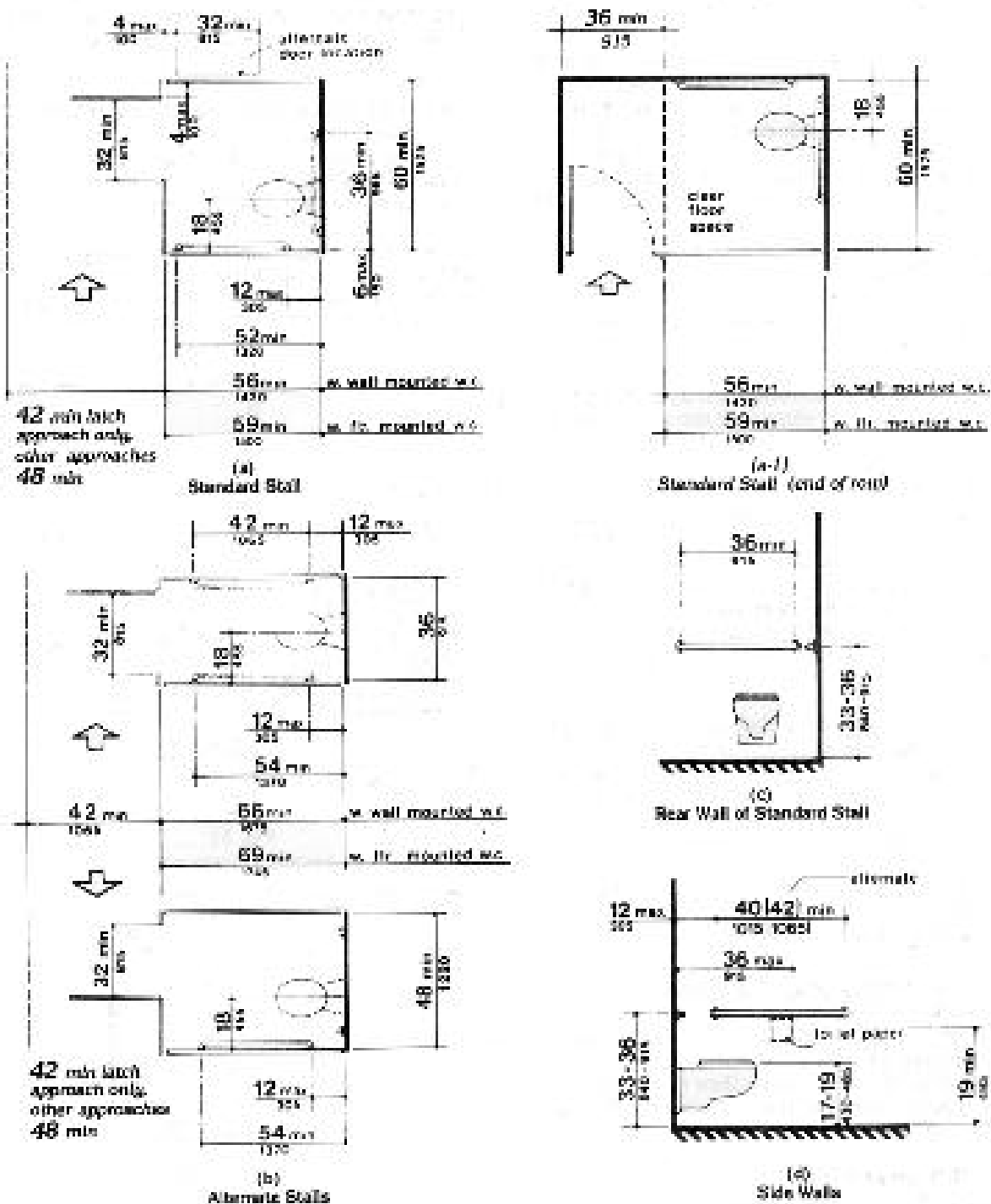

Figure 29
Grab Bars at Water Closets

Fig. 29(a) Back Wall. A 36 inch (915 mm) minimum length grab bar is required behind the water closet mounted at a height between 33 and 36 inches (840-915 mm). The grab bar must extend a minimum of 12 inches (305) beyond the center of the water closet toward the side wall and a minimum of 24 inches (610 mm) toward the open side for either a left or right side approach.



**Figure 30
Toilet Stalls**

Figure 32
Clear Floor Space at
Lavatories

The minimum depth of the lavatory is 17 inches (430

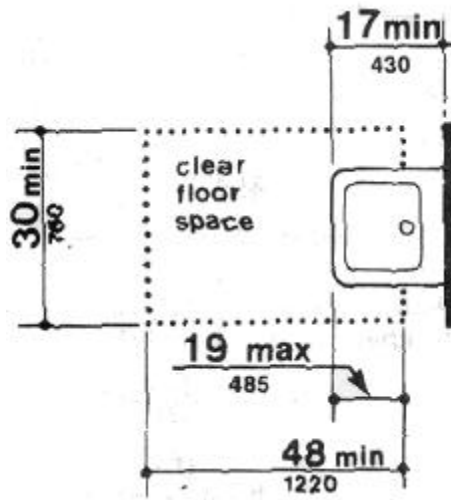

mm). (4.19.3, 4.24.5)

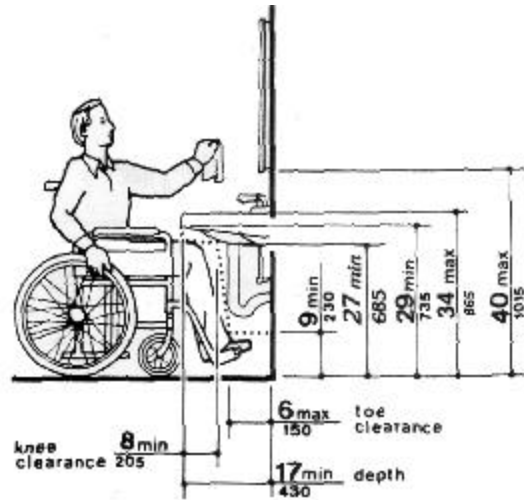

Figure 31
Lavatory Clearances

In addition to clearances discussed in the text, the following knee clearance is required underneath the lavatory: 27 inches (685 mm) minimum from the floor to the underside of the lavatory which extends 8 inches (205 mm) minimum measured from the front edge underneath the lavatory back towards the wall; if a minimum 9 inches (230 mm) of toe clearance is provided, a maximum of 6 inches (150 mm) of the 48 inches (1220 mm) of clear floor space required at the fixture may extend into the toe space. (4.19.2, 4.19.6)

THE NEW JERSEY ARTS ACCESS TASK FORCE

The *New Jersey Arts Access Task Force* was created in 1992 to assist all cultural arts organizations in making their programs and facilities accessible to individuals with disabilities. The *Arts Access Task Force* is comprised of individuals with specific knowledge and expertise in areas relating to accessible programming and facilities. Since its inception, the *Arts Access Task Force* has been a resource for New Jersey's arts community to use as they make structural and programmatic changes in order to comply with the Americans with Disabilities Act (ADA). All of the *Arts Access Task Force's* programs and services are made possible by the New Jersey State Council on the Arts/ Department of State, a partner agency of the National Endowment for the Arts.

The *New Jersey Arts Access Task Force* provides:

- ***Technical Assistance Workshops*** – These workshops, offered throughout New Jersey, provide training and technical information to assist in the creation of a strong long-range ADA plan. Topics include architectural assessment, the development of programs and services that provide inclusion of people with disabilities, development of accessible marketing publications, staff and board sensitivity training, and overview of ADA law.
- ***Self-Assessment Surveys*** – A user-friendly survey helps identify areas of your operation that are and are not accessible and what is readily achievable regarding access. The survey will also act as a guide as you develop your long-range ADA plan.
- ***Referral and Information Services*** – If you have specific questions with regards to sign-interpretation, architectural access, employment issues, etc. the *Arts Access Task Force* will provide appropriate information or the resources to find it.
- ***Review of ADA Long-Range Plans*** – Members of the *Arts Access Task Force* will review ADA plans prior to their submission to the New Jersey State Council on the Arts. Comments and suggestions will be made to applicants as to how they can improve the plan and what elements need clarification. (This service is available only to first time applicants to the NJSCA and does not guarantee the plan's approval by an independent panel review process.)
- ***CULTURAL ACCESS NEWS*** – This semi-annual publication informs the arts community about the latest advancements and accomplishments in arts accessibility in New Jersey and across the nation. Special features highlight valuable tools and programs that will assist in the implementation of your organization's ADA plan.
- ***DISCOVER JERSEY ARTS ACCESSIBILITY GUIDE*** – This companion piece to the *Discover Jersey Arts Resource Guide* is designed to assist patrons with disabilities and their families in determining the physical and programmatic accessibility of New Jersey's cultural institutions. A "snapshot" of each organization's accessibility is provided via the International Access Symbols, which were determined from responses to a survey asking pertinent questions relating to the ADA Accessibility Guidelines.

For more information on any of the services listed above, please contact *Arts Access Task Force* coordinator Wendy Liscow at 973/ 593-0189 or WLiscow@njtheatrealliance.org

NEW JERSEY ASSOCIATION OF COUNTY OFFICES FOR THE DISABLED

<http://www.njddc.org/countyoffices.htm>

The NJACOD is a representative body of Counties within New Jersey that provides a variety of services to persons with disabilities through the Offices of the Disabled/Handicapped. These offices provide: information and referral, technical assistance on ADA and other laws which impact persons with disabilities, client advocacy, community education and other services depending upon the individual county. These services allow Board of Freeholders to assist in the quality of life for persons with disabilities. Member counties include:

Atlantic County Office for the Disabled

Kathy Quish, Director
(609) 645-7700 x4519

Bergen County Office on the Disabled

Jim Thebery, Director
(201) 336-6509

Burlington County Office on Human Services

Jay Jones, PASP Coordinator
(609) 265-5223

Camden County Disabled Consumer Services

Lewis R. Friedner, Director
(856) 225-5232 (856) 225-8889 TTY

Cumberland County Office for the Disabled

David J. Grennon, Jr., Director
(856) 825-8707 v/TTY

Essex County Office on the Handicapped

Sally Goodson, Acting Director
(973) 228-8230 (973) 228-8278 TTY

Gloucester County Office for the Disabled

Jacquelyn Love, Director
(856) 384-6980 (856) 848-6616 TTY

Hunterdon County Dept. of Human Services

Barbara Metzger, Disability Planner
(908) 788-1372v/TTY

Mercer County Office for the Disabled

Thomas E. Shaw, Director
(609) 989-6468 (609) 989-6865v/TTY

Middlesex County Office for the Disabled

Lawrence Rivera, Director
(732) 745-4013 v/TTY

Monmouth County Office on Disabilities

Alexander Buono, Executive Director
(732) 431-7399 (732) 431-2066v/TTY

Morris County Office for the Disabled

Christina Brino Director
(973) 285-6855 v/TTY

Ocean County Office for the Disabled

Donnalee Snyder, Office Manager
(732) 506-5062 v/TTY

Passaic County Human Services Department

Kathy Ophhof, Director
(973) 881-4559

Salem County Office for the Disabled

Karen Richards, OFD Coordinator
(856) 935-7510, ext.8316

Somerset County Office for the Disabled

John J. Getsy, Coordinator
(908) 231-7179 (908) 231-7168 TTY

Sussex County Office for the Disabled

Maureen Babula, Director
(973) 579-0560 (973) 383-8247 TTY

Union County Office for the Disabled

Charles Newman, Director
(908) 527-4840v/TTY

Warren County Office for the Disabled

(908) 689-6000 ext.254

Division on Disability Services

1.888.285.3036

INDEPENDENT LIVING CENTERS OF NEW JERSEY

New Jersey Statewide Independent Living Council Headquarters
c/o MOCEANS CIL

279 Broadway, 1st Fl
Long Branch, NJ 07740
CHAIR: Patricia K. McShane
Telephone: 732-571-3703
Facsimile: 732-571-3003
SILC E-mail: njil@njil.org

<http://www.njil.org>

Total Living Center, Inc. (TLC)

Serving the County of Atlantic

Carolyn Silvestro, Executive Director
402 A White Horse Pike, PO Box 342
Egg Harbor City, NJ 08215
Telephone: (609) 965-3734
TTY: (609) 965-5390
Facsimile : (609) 965-1270
E-Mail: totalctr@bellatlantic.net

Heightened Independence & Progress, Inc (HIP)

Serving the County of Bergen

Eileen Goff, Executive Director
131 Main Street, Suite 120
Hackensack, NJ 07601
Telephone: (201) 996-9100
TTY: (201) 996-9424
Facsimile: (201) 996-9422
E-Mail: ber@hipcil.org

Resources for Independent Living, Inc. (RIL)

Serving the County of Burlington

Pam Reid, Executive Director
126 Franklin Street
Riverside, NJ 08075
Telephone: (856) 764-2745
TTY: (856) 461-3482
Facsimile: (856) 764-5573
E-Mail: pried@rilnj.com

Center for Independent Living of South Jersey, Inc (CILSJ)

Serving the counties of Gloucester and Camden

Hazel Lee-Briggs, Executive Director
1200 Delsea Drive
Plaza 47, Suite 6
Westville, NJ 08093
Telephone: (856) 853-6490
TTY: (856) 853-7602
Facsimile: (856) 853-1466
E-mail: CILSJ@aol.com

Camden City Independent Living Center, Inc.

Serving Camden City & surrounding areas

Lorraine Culbertson, Executive Director
2600 Mt. Ephraim Ave., Suite 413
Camden, NJ 08104
Telephone: (856) 966-0800
TTY: (856) 966-0830
Facsimile: (856) 966-0832
E-Mail: camdencil@aol.com

Tri-County Independent Living Center, Inc.

Serving the counties of Cape May, Cumberland and Salem

Pam Elliott , Executive Director
120 North High Street, #12
Millville, NJ 08332
Telephone: (856) 327-5177
TDD: (856) 327-5328
Facsimile: (856) 327-5153
E-Mail: TCILC@aol.com

Disabled Information Awareness and Living, Inc. (DIAL)

Serving the Counties of Essex and Passaic

John Petix, Jr., Executive Director
66 Mount Prospect Avenue
Building C
Clifton, NJ 07013
Voice: (973) 470-8090
TTY: (973) 470-2521
Facsimile: (973) 470-8171
E-Mail: dial_inc@yahoo.com

Disabled Information Awareness and Living, Inc. (DIAL) (Satellite Office)

Serving the City of Newark

Frances Grant, IL Program Coordinator
c/o DVRS
124 Halsey Street
Newark, NJ 07101
Voice: (973) 648-2598
TTY: (973) 624-6900
Facsimile: (973) 648-3902

Heightened Independence and Progress, Inc. (HIP) - Hudson Branch

Serving the County of Hudson

Kathy Wood, Director
2815 Kennedy Blvd.
Suite 2G
Jersey City, NJ 07306
Telephone: (201)413-1200
TTY: (201) 413-0521
Facsimile:(201) 413-0520
E-mail: hud@hipcil.org

Progressive Center for Independent Living, Inc. (PCIL)

Serving the Counties of Hunterdon and Mercer

Scott Elliot, Executive Director
831 Parkway Avenue, Unit 2B
Ewing, NJ 08618
Telephone: (609) 530-0006
TTY: (609) 530-1234
Facsimile: (609) 530-1166

E-Mail: pcil@njil.org

Hunterdon Satellite Office:

Heather Gavy, IL Program Coordinator
89 Park Avenue
Flemington, NJ 08822
Telephone: (908) 782-1055
TTY: (908) 782-1081
Facsimile: (908) 782-6025
E-Mail: Heather.Gavy@pcil.org

Alliance for Disabled In Action, Inc. (ADA)

Serving the counties of Middlesex, Somerset and Union.

Executive Director
Lower Level Suite
629 Amboy Avenue
Edison, NJ 08837
Voice: (732) 738-4388
TTY: (732) 738- 9644
Facsimile: (732) 738-4416
E-Mail: adacil@adacil.org

MOCEANS Center for Independent Living, Inc.

Serving the Counties of Monmouth & Ocean

Patricia K. McShane, Executive Director
279 Broadway, 1st Floor
Long Branch, NJ 07740
Telephone: (732) 571-4884
TDD: (732) 571-4878
Facsimilie: (732) 571-4003
E-Mail: moceans@moceans.org

Disabled Advocates Working for Northwest, Inc. (DAWN)

Serving the Counties of Monmouth & Ocean

Carmela Slivinski, Executive Director
400 South Main Street, Suite 3
Wharton, NJ 07885
Voice: (973) 361-5666
TDD: (973) 361- 6032
Facsimile: (973) 361-7086
E-Mail: dawninc@nac.net

Resources for Developing Accessible Web Sites

DO-IT (Disabilities, Internetworking and Technology) hosts a rich collection of resources, including links to Internet resources for accessible Web design.

<http://www.washington.edu/doit/>

EASI's (equal Access to Software and Information) Web site provides information related to serving patrons with disabilities including accessible Web design.

<http://www.isc.rit.edu/-easi/>

The National Center for Accessible Media (NCAM) promotes the use of a Web Access symbol and provides examples of accessible pages. NCAM also contains valuable resources on providing captions to streamed video resources.

<http://www.wgbh.org/wgbh/pages/ncam/webaccess/index.html>

A-Prompt, developed by the University of Toronto and The Trace Research and Development Center, is a tool for Web authors that works with existing HTML editors.

<http://aprompt.snow.utoronto.ca/>

Java accessibility resources are discussed at Sun Microsystems' Enabling Technologies Program.

<http://www.sun.com/access>

The Trace Research and Development Center provides resources for the design of accessible Web pages including applet and plug-in features.

<http://www.trace.wisc.edu/>

W3C's Web Accessibility Initiative outlines the strategies and tools for creating web sites that are highly usable.

<http://www.w3.org/WAI/>

Make Your Web Page Accessible: General Services Administration

<http://www.itpolicy.gsa.gov/cita/wpa/html>

Top Ten Mistakes in Web Design: Written by Jakob Nielsen, this article outlines 10 common

sense mistakes made in web design.

<http://www.useit.com/alertbox/9605.html>

All Things Web: Accommodating Imperfection. Design issues for persons with disabilities.

<http://pantos.org.atw>

Frequently Asked Questions on Web Content Accessibility Guidelines (WCAG) Answers twenty of the most commonly asked questions about WCAG

<http://www.w3.org/TR/1999/WAI-Webcontent-19990505>

WAI Quick Tips Reference Card - An introduction to the key concepts of accessible web design

<http://www.w3.org/WAI/References/QuickTips/>

Getting Started: Making a Web Site Accessible - A resource for learning and understanding Web Accessibility.

<http://www.w3.org/WAI/gettingstarted>

HTML Writers Guild's Accessible Web Authoring Resources and Education (AWARE) Center

<http://aware.hwg.org>

Alliance for Technology Access: Designing Access to WWW pages

<http://www.ataccess.org/design.html>

WGBH's National Center for Accessible Media

<http://www.wgbh.org/wgbh/pages/ncam/>

IBM Accessibility Guidelines. A similar list with some of the WAI's language made less technical.

<http://www-3.ibm.com/able/accessweb.html>

Make your website accessible to ALL your visitors

<http://www.waller.co.uk/access.htm#keyboard>

Museums and the Americans With Disabilities Act (ADA)

Reference Library

This list focuses on resources specifically written for museums and related institutions. For a copy of the Act or general information about the Act, contact the [U.S. Department of Justice Disability Rights Section](#) or read Chapter 1 "ADA Basics for Museums" in *Everyone's Welcome* listed below.

Publications Available from the American Association of Museums Bookstore:

<http://www.aam-us.org>

- *Everyone's welcome: The Americans with Disabilities Act and Museums*, AAM, 1998.
- *Standards Manual for Signs and Labels*, AAM/Metropolitan Museum of Arts, 1995.
- *The Accessible Museum: Model Programs of Accessibility for Disabled and Older People*, AAM, 1992.
- *Art Beyond Sight: A Resource Guide to Arts, Creativity, and Visual Impairment*, Art Education for the Blind/American Foundation for the Blind, 2002.
- *What Museum Guides Need to Know: Access for blind and Visually Impaired Visitors*, American Foundation for the Blind, 1989.

Other Resources:

Exhibit and Program Design

- *Accessible Exhibitions: Testing the Reality*, Smithsonian Institution, 1993.
Smithsonian Accessibility Program
- *Design for Accessibility: An Arts Administrator's Guide*, National Assembly of State Arts Agencies and the National Endowment for the Arts, 1994.
[National Assembly of State Arts Agencies](#)
- *Design Guidelines for Accessible Outdoor Recreation Activities*, Parks Canada, 1994.
[Canadian Paraplegic Association](#)
- *Design Guidelines for Media Accessibility*, Parks Canada, 1994.
[Canadian Paraplegic Association](#)
- *Equal Access: Smithsonian Publications and Events*, Smithsonian Institution, 1994.
[Smithsonian Accessibility Program](#)
- *Everyone's Nature: Designing Interpretation to Include All*, Carol Hunter, Falcon Press, 1994. Falcon Press 800/582-2665
- *Sensory Tours for People with Disabilities: A Workbook*, The Taft Museum, 1995.
[Taft Museum](#) 513/241-0343

FM Assistive Listening Equipment Available For Loan

The NJ Division of the Deaf and Hard of Hearing and The Deaf and Hard of Hearing Awareness Program of The New Jersey Library for the Blind and Handicapped have established “The Assistive Technology Loan Program”.

Do you have trouble hearing everything when attending a meeting? What about when you go to a doctor’s appointment? And how about attending library programs? Why not try an FM System to make communication more clear and effective?

Through the generosity of the NJ Division of the Deaf and Hard of Hearing, the Deaf and Hard of Hearing Awareness Program at the NJ Library for the Blind and Handicapped has been able to purchase FM Assistive Listening Equipment. These systems are now available for loan, free of charge, at the six library locations listed. They are for individual and library use, personal and large room.

The libraries below will be happy to assist you.

Gloucester County Library
389 Wolfert Station Road
Mullica Hill, NJ
856-223-6000

NJ Library f/t Blind & Handicapped
2300 Stuyvesant Avenue
Trenton, NJ
609-530-3957 Voice
877-882-5593 TTY

Montclair Public Library
50 South Fullerton Avenue
Montclair, NJ
973-744-0500

Ocean County Library
101 Washington Street
Toms River, NJ
732-349-6200

Morris County Library
30 East Hanover Avenue
Whippany, NJ
973-285-6930

Piscataway Public Library
500 Hoes Lane
Piscataway, NJ
732-463-1633

For more information, contact the Library for the Blind and Handicapped or another library listed above.